

EV On-Board DC-DC Converter



Features

- Programmable battery charging current
- Input reverse polarity protection
- CAN2.0B interface
- Bootloader via CAN bus
- IP67 enclosure, liquid cooling
- Full set of protections

Absolute Maximum Rating

Excessive stresses over these absolute maximum ratings can cause damage to the converter. Operation should be limited to the conditions outlined under the Electrical Specification Section.

Parameter	Min	Max	Unit
Input Voltage (continuous)	-900	900	V
Operating Temperature (case)	-40	85	°C
Storage Temperature	-55	125	°C

Electrical Specifications

These specifications are valid over the converter's full range of input voltage, output voltage, output current, and operating temperature unless noted otherwise.

Input Specifications

Parameter	Min	Typical	Max	Unit
Input Voltage	400	600	850	V
Input Current	-	-	15	A
Voltage at VCC Pin	11	12	18	V
Current Draw of VCC Pin (standby)	0.2	0.3	0.4	A
Current Draw of VCC Pin (normal operation)	1.0	1.1	1.2	A
ENABLE High	7	12	18	V
ENABLE Low	0	1.0	1.5	V

Output Specifications

Parameter	Min	Typical	Max	Unit
Output Voltage Set Point (software adjustable)	11	14	15	V
Output Voltage Set Point Accuracy (typical Vin, full load, Ta = 25°C)	-	-	±2%	-
Output Voltage Set Point Accuracy (over all conditions)	-	-	±2%	-
Output Ripple and Noise Voltage (peak-to-peak, 5 Hz to 20 MHz bandwidth, typical Vin)	-	-	500	mVp-p
Output Current (software adjustable)	5	-	368	A
Output Current Set Point Accuracy (typical Vin, Ta = 25°C)	-	-	±2%	-
Output Power	-	-	5.0	kW
Efficiency				
Typical Vin; 20% of full load, Ta = 25°C	-	90.5	-	%
Typical Vin; 50% of full load, Ta = 25°C	-	93.5	-	
Typical Vin; 100% of full load, Ta = 25°C	-	93.0	-	
Output Ripple Frequency	200	230	250	kHz
Dynamic Response (typical Vin; Ta = 25°C; load transient 0.1A/μs)				
Load step from 25% to 75% of full load:				
Peak deviation	-	4	-	%Vo
Settling time (to 10% band of Vo deviation)	-	4	-	ms
Load step from 75% to 25% of full load:				
Peak deviation	-	4	-	%Vo
Settling time (to 10% band of Vo deviation)	-	4	-	ms
Turn-on Time (from applying DC input to Vo=90%)	-	200	-	ms

General Specifications

Parameter	Min	Typical	Max	Unit
Ingress Protection	IP67			
Isolation Capacitance	-	6,600	-	pF
Dimensions	385.50 x 286.50 x 61.00			mm
Weight	-	5.3	-	kg
Operating Humidity	5	-	95	%RH
On/Off DC-DC converter	CAN command			

Cooling Specifications

Parameter	Description
Cooling Style	Liquid cooling, coolant temperature less than 65°C
Coolant Medium/Mixture	50/50 Ethylene Glycol/Water
Coolant Volume in Cooling System	280ml
Minimum Coolant Flow	See Figure 1
Pressure Drop	See Figure 2

Protection Specifications

Parameter	Notes	Min	Typical	Max	Unit
Input Under-voltage Protection		375	380	385	V
Input Under-voltage Recovery	Auto-recovery	385	390	395	
Input Over-voltage Protection		865	870	875	
Input Over-voltage Recovery	Auto-recovery	855	860	865	
Output Under-voltage Protection		-	9	-	
Output Under-voltage Recovery	Auto-recovery	-	10	-	
Output Over-voltage Protection		-	16.5	-	
Output Over-voltage Recovery	Auto-recovery	-	15.5	-	
Output Over-current Protection	Current limiting mode	-	-	386	A
Output Short-Circuit Protection	Auto-recovery				
Over Temperature Protection		100	105	110	°C
Over Temperature Recovery	Auto-recovery	90	95	100	

Safety Specifications

Parameter	Notes	Min	Typical	Max	Unit
Isolation Voltage	Input-Output/Case, 1 minute, <5mA	2,800	-	-	Vdc
Insulation Resistance	Input-Output, 1000Vdc, 90% RH, nominal air pressure	200	-	-	MΩ
	Input-Case, 1000Vdc, 90% RH, nominal air pressure	200	-	-	

Communication Specifications

Parameter	Description
Interface	Based on CAN2.0B interface at 500Kbps baud rate
Protocol	NetPower standard protocol
Functions	Turn on/turn off DC-DC converter
	Set output voltage
	Set maximum output current limit
	Monitor real-time parameters (voltages, currents and temperature) and faults
	Bootloader software

Customization Specifications

Parameter	Description
Parallel	Multiple DC-DC converters can operate in parallel to provide higher output power
CAN Communication Baud Rate	Choice of: 125kbps, 250kbps, 500kbps (default) or 1000kbps
UDS Diagnostic and Bootloader	ISO 14229 Road Vehicles—Unified Diagnostic Services (UDS) ISO 15765 Road Vehicles—Diagnostics on Controller Area Networks (CAN)
J1939 Communication, Diagnostic and Bootloader	SAE J1939-21 Data Link Layer SAE J1939-71 Vehicle Application Layer SAE J1939-73 Application Layer—Diagnostics SAE J1939-81 Network Management
Customized Protocol	According to customer requirements

Interface Definitions

Connector	Connector Model	
	Receptacle	Plug
HVDC Input	HVC2P28MV404	HVC2P28FS404
	Supplier: Amphenol Automotive	
LVDC Output	Bus bar terminals	
Signal	LPT02SE-12-8P(023)(LC)	LPT06SE-12-8S(023)(LC); LPTC-SF-20S-20-1
	Supplier: Amphenol	

HVDC Input Connector Descriptions

Pin	Name	Description	Model: HVC2P28MV404 Supplier: Amphenol Automotive
1	Vin+	Input voltage +	
2	Vin-	Input voltage -	
3	HVIL-	High voltage interlock -	
4	HVIL+	High voltage interlock +	

Note: "HVIL+" and "HVIL-" are shorted together once the mating side is properly plugged in this connector.

Signal Connector Descriptions

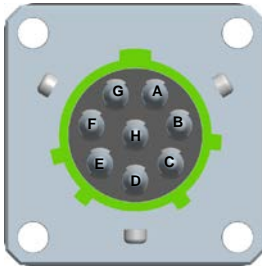
Pin	Name	Description	Model: LPT02SE-12-8P(023)(LC) Supplier: Amphenol
A	ENABLE	Enable DC-DC converter	
B	HVIL+	High voltage interlock +	
C	HVIL-	High voltage interlock -	
D	VCC+	Auxiliary power input positive	
E	NC	No connection	
F	VCC-	Auxiliary power input negative	
G	CAN_H	CAN high	
H	CAN_L	CAN low	

Note: "HVIL+" and "HVIL-" are output signals that are internally connected with "HVIL+" and "HVIL-" in the input connector respectively.
 No internal 120ohm CAN termination resistor.

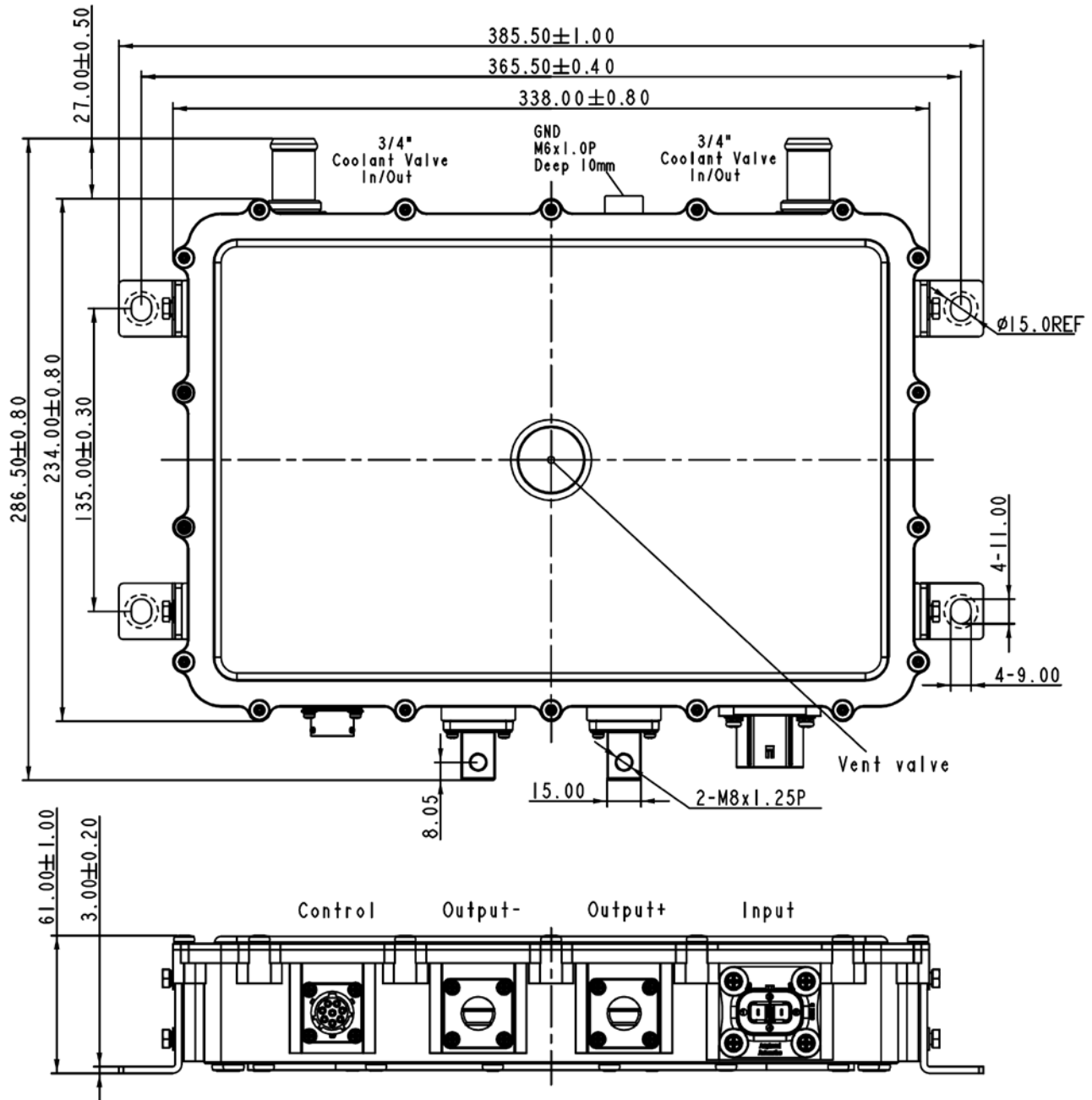
Mechanical Drawing

Notes:

- 1) All dimensions in mm
- 2) Outputs are bus bar terminals, Tin Bronze material with Tin under plating, tightening torque: M8, 25N·m.



Appendix I

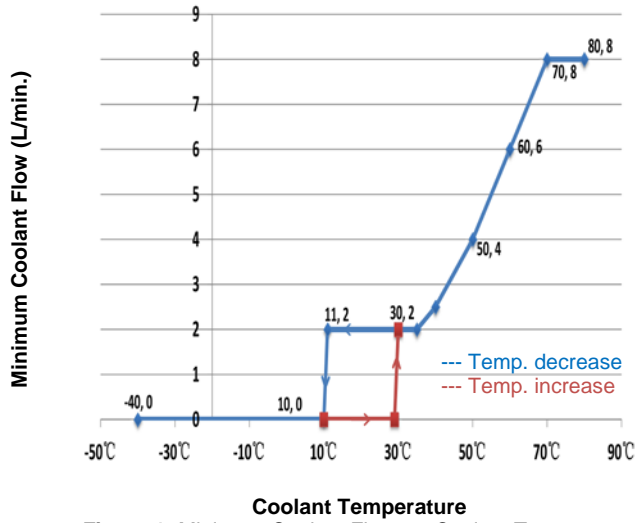

Figure 1: Minimum Coolant Flow vs. Coolant Temperature

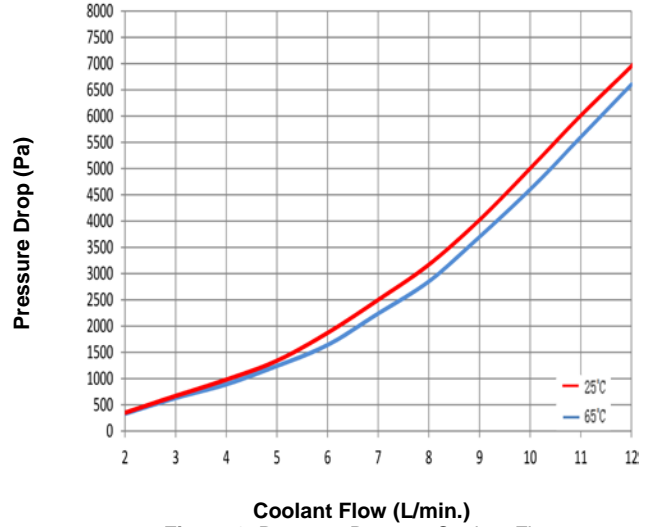

Figure 2: Pressure Drop vs. Coolant Flow

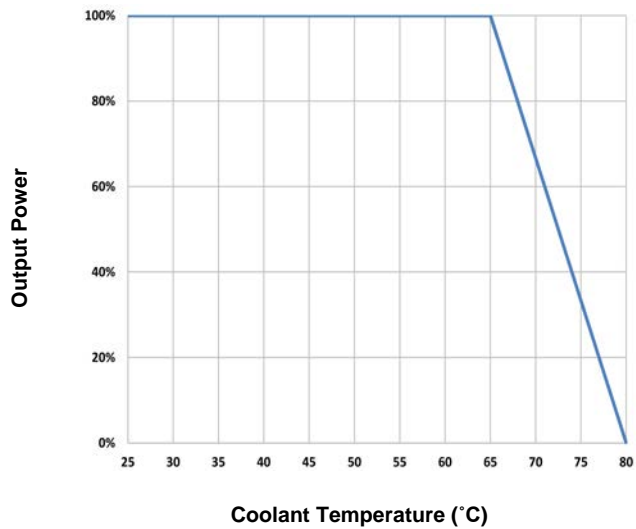

Figure 3: Power Derating Curve