

ISOCOM[®]

L I M I T E D

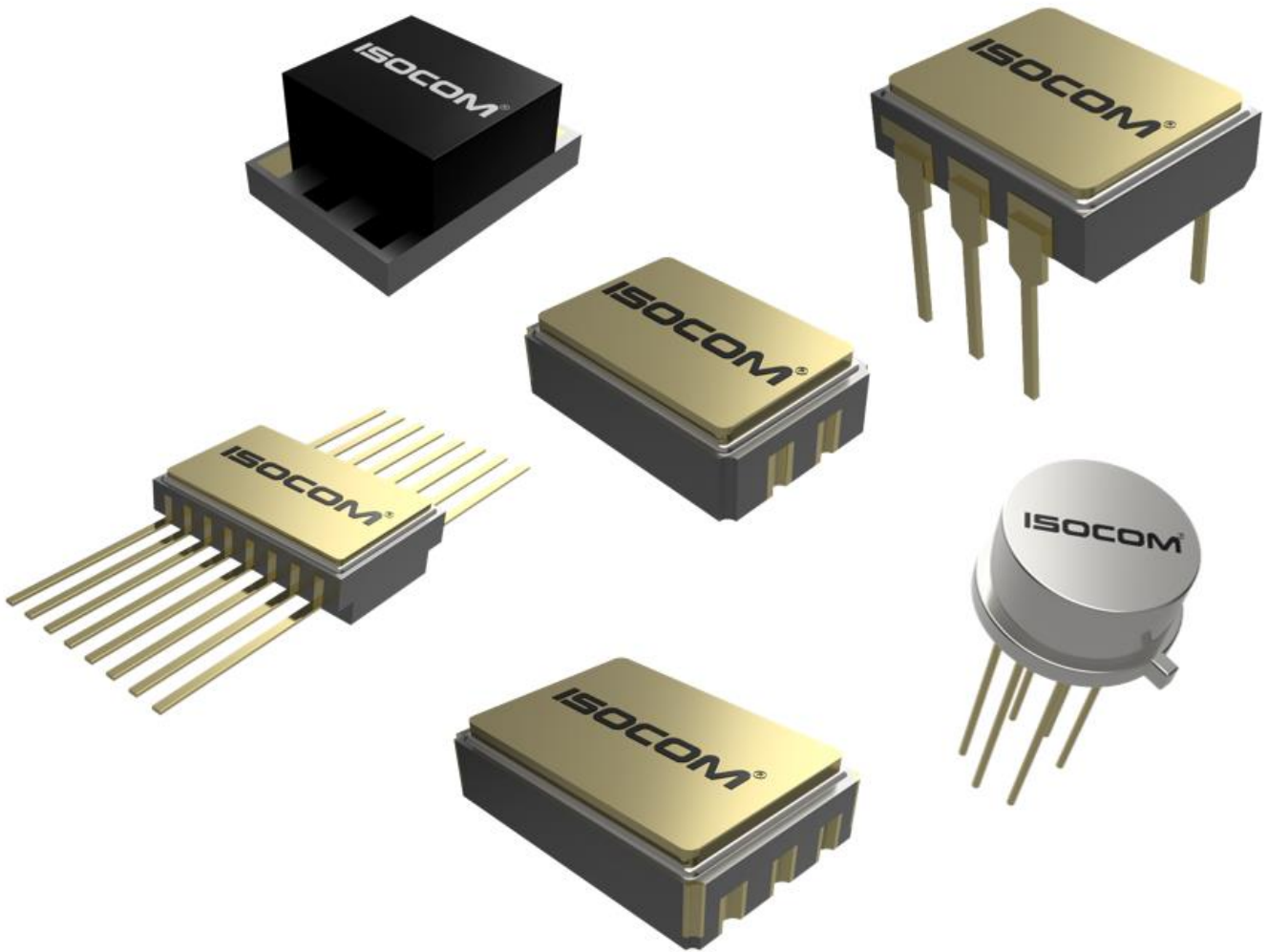

OPTOCOUPLER SELECTION GUIDE

ISOCOM LIMITED FACILITIES AND CAPABILITIES

Isocom Limited, based in the North East of England, specialises in Custom Packaging and Hybrid Assembly Design with clean room manufacturing including wire bonding, die attaching and lid sealing. Our screening facilities and test capabilities include:

- ATE and bench test equipment for all component parameters
- High temperature handlers
- High/Low temperature forcing
- Die wafer probing
- High magnification inspection stations
- Acceleration tests to 30,000G
- Vibration test to MIL and DESC levels
- Solderability tests
- Fluorocarbon pressurisation and gross and fine leak tests
- Endurance tests and environmental tests, including Temperature Cycling and various Burn-in processes
- Particle Impact Noise Detector (PIND) testing
- Hermetic Sealing of components
- Full production equipment for Hybrid and PCB assemblies
- Conceptual design to final production: components and systems
- Ceramic and metal product design.



We would welcome the opportunity to discuss how we can help you achieve your custom design requirements. Our contact details are set out below.

Contents

Index of Radiation Hard Ceramic Optocouplers.....	3
Ceramic Hermetically sealed Transistor Optocouplers.....	5
Ceramic Hermetically sealed AC Transistor Optocouplers.....	8
Ceramic Hermetically sealed High-Speed Transistor Optocouplers.....	9
Ceramic Hermetically Sealed High Gain Optocouplers	11
Ceramic Hermetically Sealed High Gain Photon Optocouplers.....	13
Ceramic Hermetically Sealed Zero Crossing Triac Optocouplers.....	15
Ceramic Hermetically Sealed Linear Optocouplers.....	15
Ceramic Hermetically sealed MOSFET Optocoupler.....	16
Ceramic Hermetically sealed Photodiode Optocoupler.....	16
Hermetic Optocoupler Surface Mount Options.....	17
Package Dimensions.....	18
Screening Flow MIL-PRF 19500.....	21
Screening Flow MIL-PRF 38534.....	22

RADIATION HARD CERAMIC OPTOCOUPLEDERS

DEVICE		DEVICE	
4N24.....	5	CS3082.....	15
4N49.....	5	CS3083.....	15
4N55.....	9	CS5700.....	12
6N134.....	13	CSL400.....	15
6N140A.....	11	CSM100.....	6
CD500.....	5	CSM120.....	8
CD501.....	5	CSM121.....	8
CD650.....	13	CSM141A.....	12
CD651.....	13	CSM150.....	16
CD750.....	11	CSM151.....	16
CD850.....	9	CSM160-2.....	12
CD5731.....	11	CSM160-4.....	12
CH100.....	5	CSM161-2.....	12
CH300.....	5	CSM161-4.....	12
CH301A.....	6	CSM162-2.....	12
CH350.....	13	CSM162-4.....	12
CH370.....	11	CSM165-2.....	7
CH380.....	9	CSM165-4.....	7
CH390.....	11	CSM166-4.....	7
CS200.....	6	CSM168-2.....	9
CS201.....	6	CSM168-4.....	10
CS224.....	6	CSM169-2.....	14
CS249.....	6	CSM169-4.....	14
CS600.....	13	CSM200.....	7
CS700.....	11	CSM452.....	12
CS800.....	9	CSM1200.....	6
CS801.....	9	CSM1224.....	7
CS3031.....	15	CSM1600.....	13
CS3032.....	15	CSM1700.....	12
CS3033.....	15	CSM1800.....	10
CS3041.....	15	CSM1801.....	10
CS3042.....	15	CSM2224.....	7
CS3043.....	15	CSMR40.....	16
CS3061.....	15	IS49.....	7
CS3062.....	15	MC600.....	14
CS3063.....	15	MC800.....	10
CS3081.....	15		

ISOCOM LIMITED RADIATION SUMMARY ON OPTOCOUPLERS

TOTAL IONIZATION DOSE TESTED – Upto 1Mrad(si)



DISPLACEMENT DAMAGE TESTED – 1MeV X 10¹²

NEUTRON TESTED - Transistors – 1.00E + 11
 High Speed – 3.00E + 12
 High Gain – 3.00E + 12
 High Gain Photon – 1.00E + 13

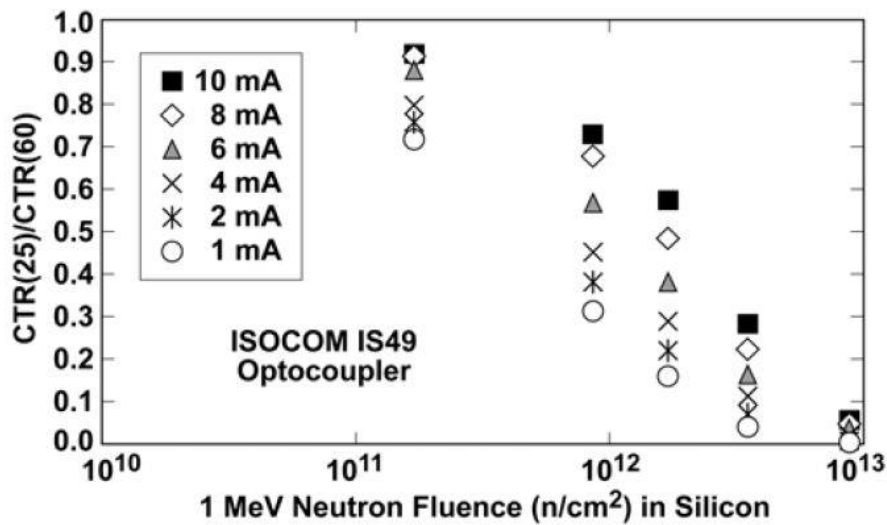
Normalized CTR versus the radiation level for the IS49

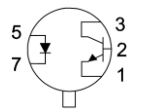
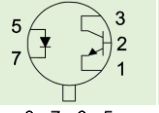
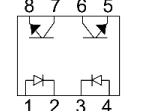

Ceramic Hermetically Sealed Transistor Optocouplers, manufactured to ISO 9001:2008 & IECQ standards, with an operating temperature range from -55°C to +125°C (RADIATION TESTED)

Part No.	Functional Diagram	Package Details	CTR (I _F = 10mA) min(%)	Continuous I _F max(mA)	V _F (I _F = 10mA) max(V)	BV _{CEO} (I _C = 1mA) min(V)	I _{CEO} (Dark) (V _{CE} = 20V) max(μA)	V _{CE} Sat (I _F = 10mA, I _C = 2mA) max(V)	Package Figure No.
4N24			350	50	1.8	100	100	0.3	Page 18 Fig.6
4N49			350	50	1.8	100	100	0.3	Page 18 Fig.6
CD500			50	50	1.5	100	100	0.22***	Page 20 Fig.10
CD501			50	50	1.5	100	100	0.22***	Page 20 Fig.10
CH100			150	40	1.8	70	100	0.3**	Please contact Isocom
CH300			350	15	1.5	30	100**	0.25*	Page 18 Fig.4

Ceramic Hermetically Sealed Transistor Optocouplers, manufactured to ISO 9001:2008 & IECQ standards, with an operating temperature range from -55°C to +125°C (RADIATION TESTED) Cont.

Part No.	Functional Diagram	Package Details	CTR (I _F = 10mA) min(%)	Continuous I _F max(mA)	V _F (I _F = 10mA) max(V)	BV _{CEO} (I _C = 1mA) min(V)	I _{CEO} (Dark) (V _{CE} = 20V) max(μA)	V _{CE} (Sat) (I _F = 10mA, I _C = 2mA) max(V)	Package Figure No.
CH301A			350	15	1.5	30	100 ⁺⁺	0.25*	Page 18 Fig.4
CS200			100	50	1.8	70	100	0.3 ^{***}	Page 19 Fig.9
CS201			100	50	1.8	70	100	0.3 ^{***}	Page 19 Fig.9
CS224			350	50	1.8	100	0.1	0.3 ^{***}	Page 19 Fig.9
CS249			200	50	1.8	70	100	0.22 ^{**}	Page 19 Fig.9
CSM100			350	40	1.6	70	100	0.22 ^{**}	Page 19 Fig.7
CSM1200			350	50	1.8	100	100	0.3 ^{**}	Page 19 Fig.8

Ceramic Hermetically Sealed Transistor Optocouplers, manufactured to ISO 9001:2008 & IECQ standards, with an operating temperature range from -55°C to +125°C (RADIATION TESTED) Cont.

Part No.	Functional Diagram	Package Details	CTR (I _F = 10mA) min(%)	Continuous I _F max(mA)	V _F (I _F = 10mA) max(V)	BV _{CEO} (I _C = 1mA) min(V)	I _{CEO} (Dark) (V _{CE} = 20V) max(μA)	V _{CE} (Sat) (I _F = 10mA, I _C = 2mA) max (V)	Package Figure No.
CSM1224			350	50	1.8	100	0.1	0.3**	Page 19 Fig.8
CSM165-2			350	50	1.6	100	0.1	0.22**	Page 20 Fig.12
CSM165-4			350	50	1.6	100	0.1	0.22**	Page 20 Fig.12
CSM166-4			100 ⁺	10	1.8	50	0.1	0.3****	Page 20 Fig.11
CSM200			350	50	1.4	100	0.1	0.22**	Page 19 Fig.8
CSM2224			350	50	1.8	100	0.1	0.3**	Page 19 Fig.8
IS49			350	50	1.8	70	100	0.22**	Page 19 Fig.8

For sales enquiries, or further information, please contact our sales office at:
 ISOCOM Limited • 2 Fern Court • Peterlee • County Durham • Tyne & Wear • SR8 2RR • United Kingdom
 Email: sales@isocom.uk.com • Tel: +44 (0)191 416 6546

* I_F = 2mA, I_C = 0.2mA
 ** I_F = 20mA, I_C = 10mA
 *** I_F = 10mA, I_C = 2.5mA
 **** I_F = 2mA, I_C = 1mA
 + I_F = 1mA
 ** V_{CE} = 10V

Ceramic Hermetically Sealed AC Transistor Optocoupler, manufactured to ISO 9001:2008 & IECQ standards, with an operating temperature range from -55°C to +125°C (RADIATION TESTED)

Part No.	Functional Diagram	Package Details	CTR ($I_F = 10\text{mA}$) min(%)	BV_{CEO} ($I_C = 1\text{mA}$) min(V)	V_F ($I_F = 10\text{mA}$) min(V)	Transition Times ($R_L = 100\Omega$)		Package Figure No.
						t_r max(μS)	t_f max(μS)	
CSM120			200	40	1.8	20	20	Page 19 Fig.7
CSM121			200	40	1.8	20	20	Page 19 Fig.8

Ceramic Hermetically Sealed High Speed Optocouplers, manufactured to ISO 9001:2008 & IECQ standards, with an operating temperature range from -55°C to +125°C (RADIATION TESTED)



Part No.	Functional Diagram	Package Details	CTR ($I_F = 16\text{mA}$) min(%)	Continuous I_F max(mA)	V_F ($I_F = 16\text{mA}$) max(V)	BW ($R_L = 100\Omega$) typ(MHz)	Propagation Delay Times ($R_L = 1.9\text{K}\Omega$, $V_{CC} = 5\text{V}$, $I_F = 16\text{mA}$)		Package Figure No.
							t_{PHL} max (μS)	t_{PLH} max (μS)	
4N55			9	20	1.7	3	2.0	6.0	Page 20 Fig.11
CD850			typ 17	20	1.7	3	0.8	0.8	Page 20 Fig.10
CH380			typ 17	20	1.7	3	0.8	0.8	Page 18 Fig.5
CS800			9	20	typ 1.45*	2	typ 0.5*	typ 0.5*	Page 20 Fig.10
CS801			15	20	typ 1.45*	2	typ 0.5*	typ 0.5*	Page 20 Fig.10
CSM168-2			9	20	1.7	3	typ 0.1	typ 0.3	Page 20 Fig.12

Ceramic Hermetically Sealed High Speed Optocouplers, manufactured to ISO 9001:2008 & IECQ standards, with an operating temperature range from -55°C to +125°C (RADIATION TESTED) Cont.

Part No.	Functional Diagram	Package Details	CTR ($I_F = 16\text{mA}$) min(%)	Continuous I_F max(mA)	V_F ($I_F = 16\text{mA}$) max(V)	BW ($R_L = 100\Omega$) typ(MHz)	Propagation Delay Times ($R_L = 1.9\text{k}\Omega$, $V_{CC} = 5\text{V}$, $I_F = 16\text{mA}$)		Package Figure No.
							t_{PHL} max (μS)	t_{PLH} max (μS)	
CSM168-4			9	20	1.7	3	typ 0.1	typ 0.3	Page 20 Fig.12
CSM1800			typ 17	20	1.7	2	0.8	0.8	Page 19 Fig.8
CSM1801			typ 17	20	1.7	2	0.8	0.8	Page 19 Fig.8
MC800			9	20	1.7	2	0.8	0.8	Page 18 Fig.6

* $R_L = 8.2\text{k}\Omega$
+ $I_F = 20\text{mA}$

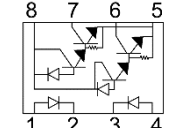
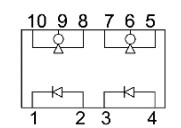





Ceramic Hermetically Sealed High Gain Optocouplers, manufactured to ISO 9001:2008 & IECQ standards, with an operating temperature range from -55°C to +125°C (RADIATION TESTED)

Part No.	Functional Diagram	Package Details	CTR ($I_F = 1.6\text{mA}$) min(%)	Continuous I_F max(mA)	V_F ($I_F = 1.6\text{mA}$) max(V)	Data Rate typ(Kb/s)	Propagation Delay Times, ($R_L = 680\Omega$, $V_{CC} = 5\text{V}$, $I_F = 5\text{mA}$)		Package Figure No.
							t_{PHL} max(μS)	t_{PLH} max(μS)	
6N140A			200	10	1.7	100	12	60	Page 20 Fig.11
CD5731			200	10	1.7	100	12	60	Page 20 Fig.10
CD750			200	10	1.7	100	12	60	Page 20 Fig.10
CH370			200	8	1.9	100	12	60	Page 18 Fig.5
CH390			200	10	1.9	100	12	60	Please contact Isocom
CS700			200	10	1.7	100	10	60	Page 20 Fig.10

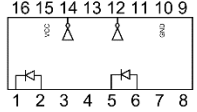

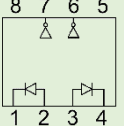
Ceramic Hermetically Sealed High Gain Optocouplers, manufactured to ISO 9001:2008 & IECQ standards, with an operating temperature range from -55°C to +125°C (RADIATION TESTED) Cont.

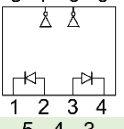
Part No.	Functional Diagram	Package Details	CTR ($I_F = 1.6\text{mA}$) min(%)	Continuous I_F max(mA)	V_F ($I_F = 1.6\text{mA}$) max(V)	Data Rate typ(Kb/s)	Propagation Delay Times, ($R_L = 680\Omega$, $V_{CC} = 5\text{V}$, $I_F = 5\text{mA}$)		Package Figure No.
							t_{PHL} max(μS)	t_{PLH} max(μS)	
CS5700			300	10	1.7	100	10	60	Page 20 Fig.10
CSM141A			300	10	1.7	700	5	20	Page 19 Fig.8
CSM160/ 161/162-2			200	10	1.7	100	5	60	Page 20 Fig.12
CSM160/ 161/162-4			200	10	1.7	100	5	60	Page 20 Fig.12
CSM1700			200	10	1.7	700	12	60	Page 19 Fig.8
CSM452			200	20	1.8	100	12	60	Page 19 Fig.7

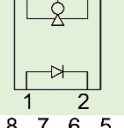
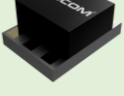
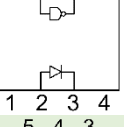
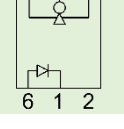
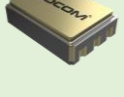
Ceramic Hermetically Sealed High Gain Photon Optocouplers, manufactured to ISO 9001:2008 & IECQ standards, with an operating temperature range from -55°C to +125°C (RADIATION TESTED)

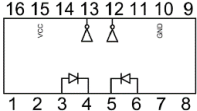
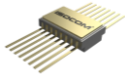
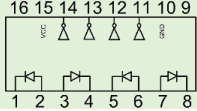
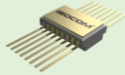
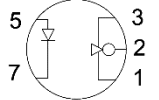

Part No.	Functional Diagram	Package Details	CTR ($I_F = 10\text{mA}$) min(%)	Continuous I_F max(mA)	V_F ($I_F = 20\text{mA}$) max(V)	Data Rate typ(Kb/s)	Propagation Delay Times ($R_L = 510\Omega$, $C_L = 15\text{pF}$, $V_{CC} = 5\text{V}$, $I_F = 13\text{mA}$)		Package Figure No.
							t_{PHL} max(ns)	t_{PLH} max(nS)	
6N134			100	20	1.9	10	90	90	Page 20 Fig.11
CD650			100 ⁺	20	1.9	10	100	90	Page 20 Fig.10
CD651			100 ⁺	20	1.9	10	90	90	Page 20 Fig.10
CH350			100	15	1.9	10	200	200	Page 18 Fig.5
CS600			100 ⁺	20	1.9	10	75 ^{**}	75 ^{**}	Page 20 Fig.10
CSM1600			100	20	1.9	10	300 [*]	1400 [*]	Page 19 Fig.8

Ceramic Hermetically Sealed High Gain Photon Optocouplers, manufactured to ISO 9001:2008 & IECQ standards, with an operating temperature range from -55°C to +125°C (RADIATION TESTED) Cont.

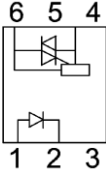

Part No.	Functional Diagram	Package Details	CTR ($I_F = 10\text{mA}$) min(%)	Continuous I_F max(mA)	V_F ($I_F = 20\text{mA}$) max(V)	Data Rate typ(Kb/s)	Propagation Delay Times ($R_L = 510\Omega$, $C_L = 15\text{pF}$, $V_{CC} = 5\text{V}$, $I_F = 13\text{mA}$)		Package Figure No.
							t_{PHL} max(ns)	t_{PLH} max(ns)	
CSM169-2			100	20	1.9	10	200	200	Page 20 Fig.12
CSM169-4			100	20	1.9	10	200	200	Page 20 Fig.12
MC600			100	20	1.9	10	300	300	Page 18 Fig.6

* $R_L = 350\Omega$, $V_{CC} = 5\text{V}$, $I_F = 7.5\text{mA}$, $C_L = 15\text{pF}$
 ** $R_L = 350\Omega$, $V_{CC} = 5\text{V}$, $I_F = 13\text{mA}$, $C_L = 15\text{pF}$
 * $I_F = 5\text{mA}$

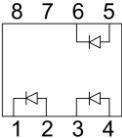

Ceramic Hermetically Sealed Zero Crossing Triac Optocouplers, manufactured to ISO 9001:2008 & IECQ standards, with an operating temperature range from -55°C to +125°C

Part No.	Functional Diagram	Package Details	V_{DRM} ($I_{DRM} = 100nA$) min(V)	Continuous I_F max(mA)	V_F ($I_F = 30mA$) max(V)	I_{FT} (Main Terminal Voltage = 3V) max(mA)	dv/dt (C) typ(V/ μ s)	Package Figure No.
CS3031/ 32/33			250	60	1.8	15 / 10 / 5	2000	Page 19 Fig.9
CS3041/ 42/43			400	60	1.7	15 / 10 / 5	2000	
CS3061/ 62/63			600	60	1.5	15 / 10 / 5	1500	
CS3081/ 82/83			800	60	1.5	15 / 10 / 5	1500	



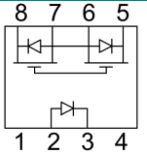

Ceramic Hermetically Sealed Linear Optocouplers, manufactured to ISO 9001:2008 & IECQ standards, with an operating temperature range from -55°C to +125°C (RADIATION TESTED)

Part No.	Functional Diagram	Package Details	BV_R ($I_R = 100\mu A$) typ(V)	V_F ($I_F = 10mA$) max(V)	Transfer Gain ($I_F = 10mA, V_R = 15V$) Typ()	Transition times ($R_L = 50\Omega, I_F = 10mA$) max(μ s)		Package Figure No.
						t_r	t_f	
CSL400			200	1.8	1.0	2	2	Page 20 Fig.10

Ceramic Hermetically Sealed MOSFET Optocoupler, manufactured to ISO 9001:2008 & IECQ standards, with an operating temperature range from -55°C to +125°C

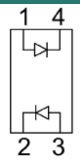
Part No.	Functional Diagram	Package Details	I _F max(mA)	R(ON) (I _F = 10mA, I _O = 500mA, t _p ≤ 30ms)		V _F (I _F = 10mA) max(V)	I _O (OFF) (V _F = 0.6V, V _O = 90V) max(μA)	Turn On/Off times (I _F = 10mA, V _{DD} = 28V, I _O = 800mA)		Package Figure No.
				A typ(Ω)	B typ(Ω)			t _{ON} max(ms)	t _{OFF} max(ms)	
CSMR40			20	0.8	0.2	1.7	10	6.0	0.25	Page 20 Fig.10

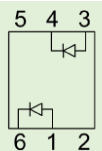
Ceramic Hermetically Sealed Photodiode Optocoupler, manufactured to ISO 9001:2008 & IECQ standards, with an operating temperature range from -55°C to +125°C (RADIATION TESTED)

Part No.	Functional Diagram	Package Details	I _D (V _R = 5V, R _L = 1MΩ) typ(μA)	BV _R (I _R = 1mA) min(V)	Transition Times (R _L = 3.3KΩ, I _F 10mA)		CTR (I _F = 10mA, V _{OUT} = 5) typ(%)	Package Figure No.
					t _r typ(nS)	t _f typ(nS)		
CSM150			100	200	200	200	1.56	Page 19 Fig.7
CSM151			100	200	200	200	1.56	Page 19 Fig.8

Hermetic Optocoupler Surface Mount Options

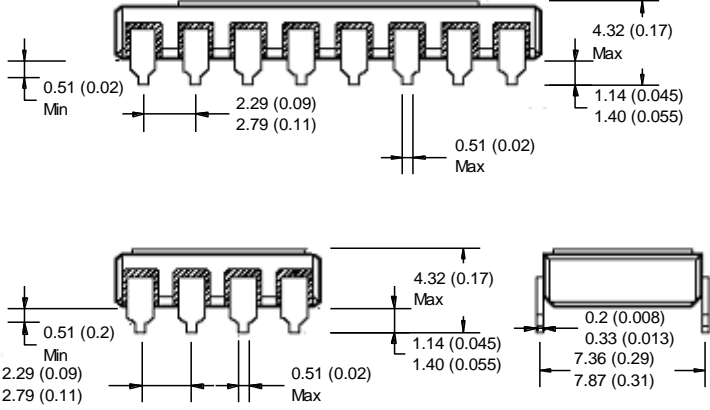
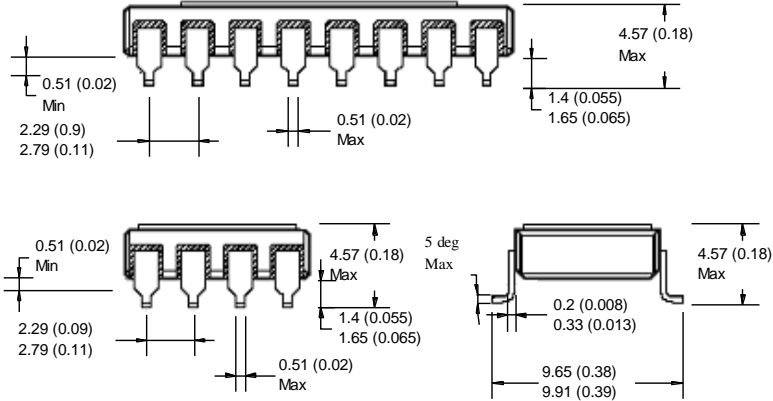
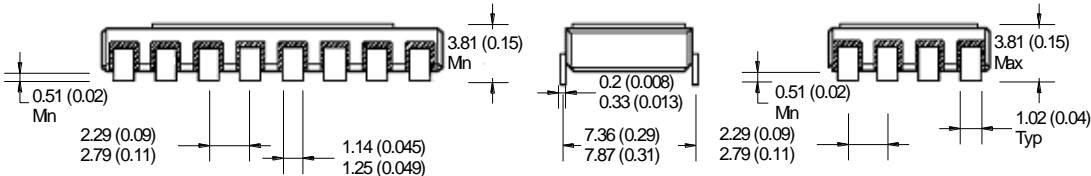
Option	Description
10	<p>Surface mountable hermetic optocoupler with leads trimmed for butt joint assembly. This option is available on commercial hi-rel product in 8 and 16 pin DIP</p>  <p style="text-align: center;">Fig. 1 8 and 16 pin DIP trimmed for butt joint assembly</p>
20	<p>Solder Dip Option</p>
30	<p>Surface mountable hermetic optocoupler with leads cut and bent for gull wing assembly. This option is available on commercial and hi-rel product in 8 and 16 pin DIP.</p>  <p style="text-align: center;">Fig. 2 8 and 16 pin DIP with leads cut and bent for gull wing assembly</p>
60	<p>Surface mountable hermetic optocoupler with leads trimmed for butt joint assembly. This option is available on commercial hi-rel product in 8 and 16 pin DIP</p>  <p style="text-align: center;">Fig. 3 8 and 16 pin DIP with leads trimmed for butt joint assembly</p>

Package Drawings (mm)

4/5 Pin Hybrid

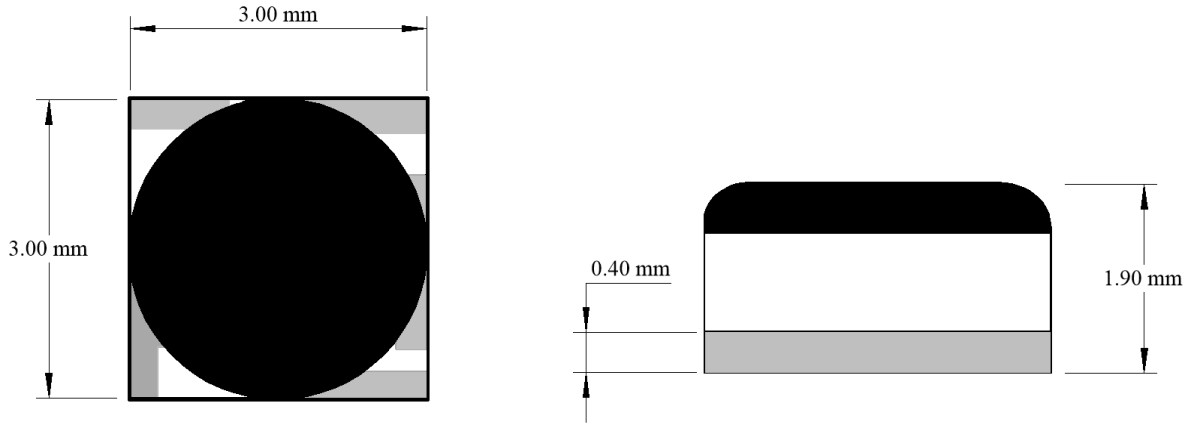

5 Pin Hybrid

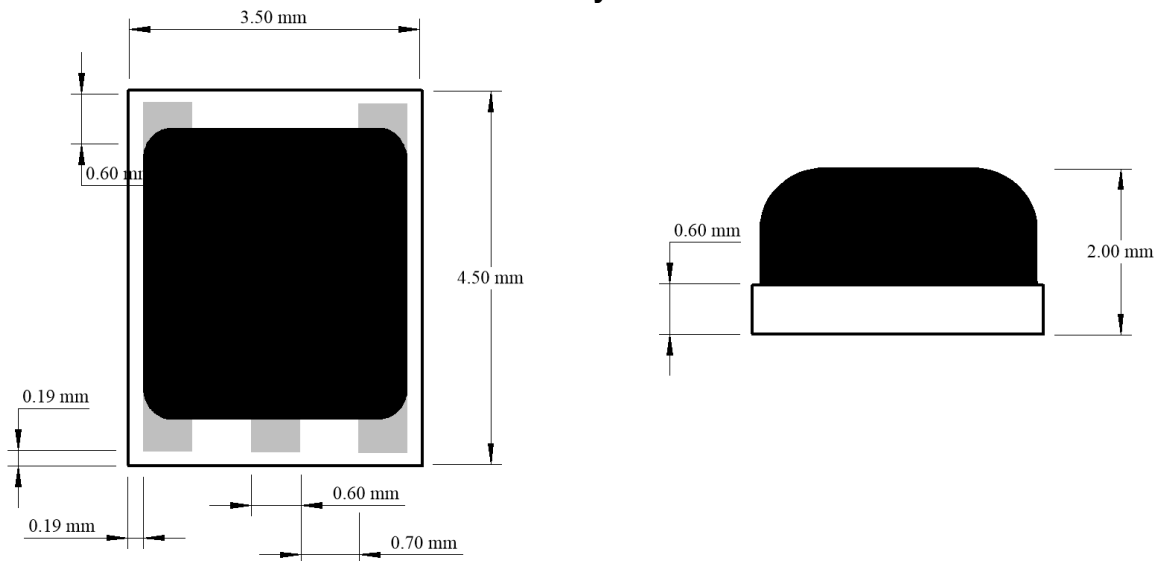

ISOCOM Package Drawings (cont.)

6 Metal Can

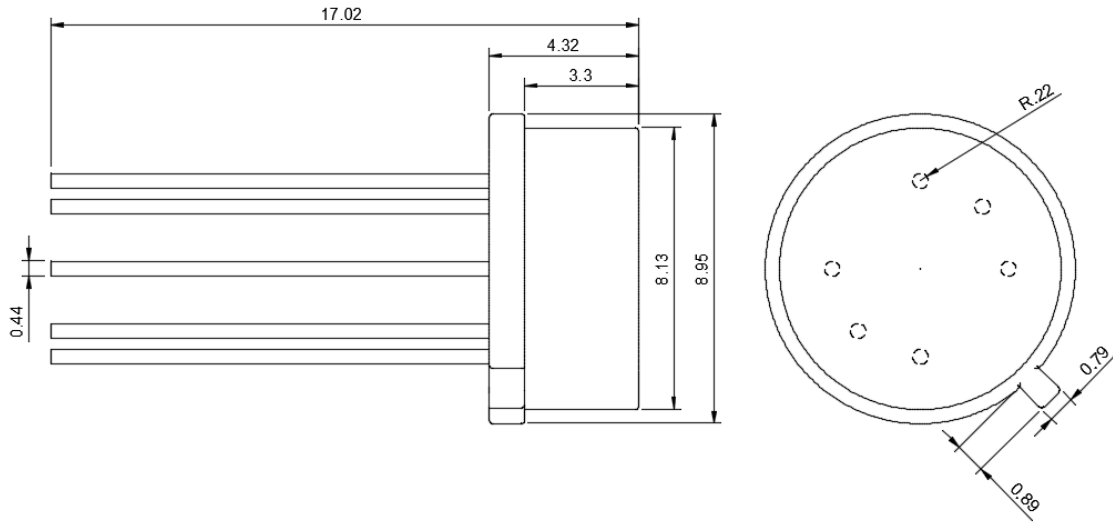

4 Pin LCC

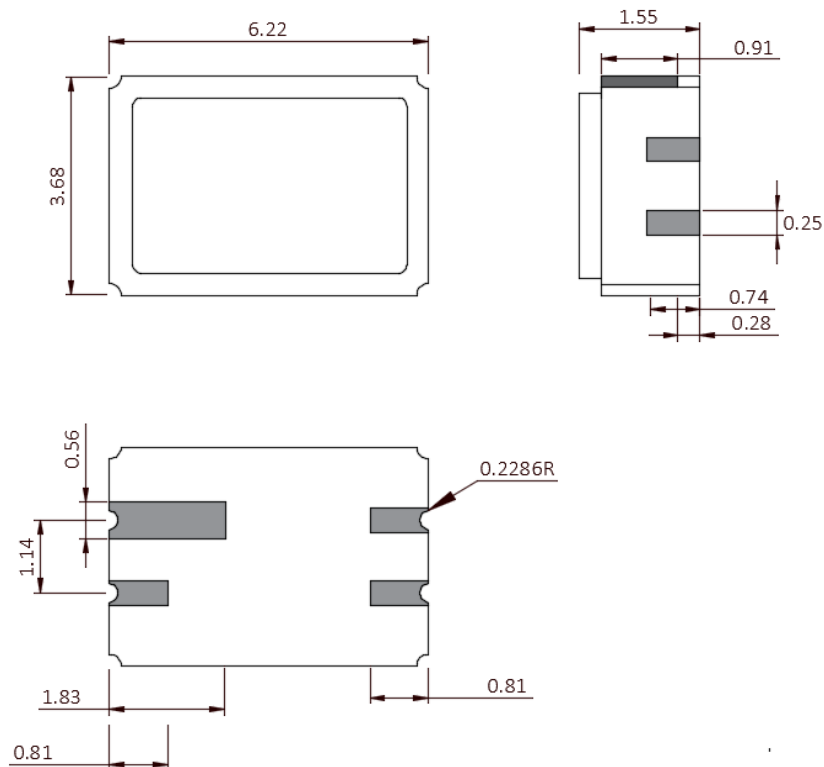

ISOCOM Package Drawings (cont.)

6 PIN LCC

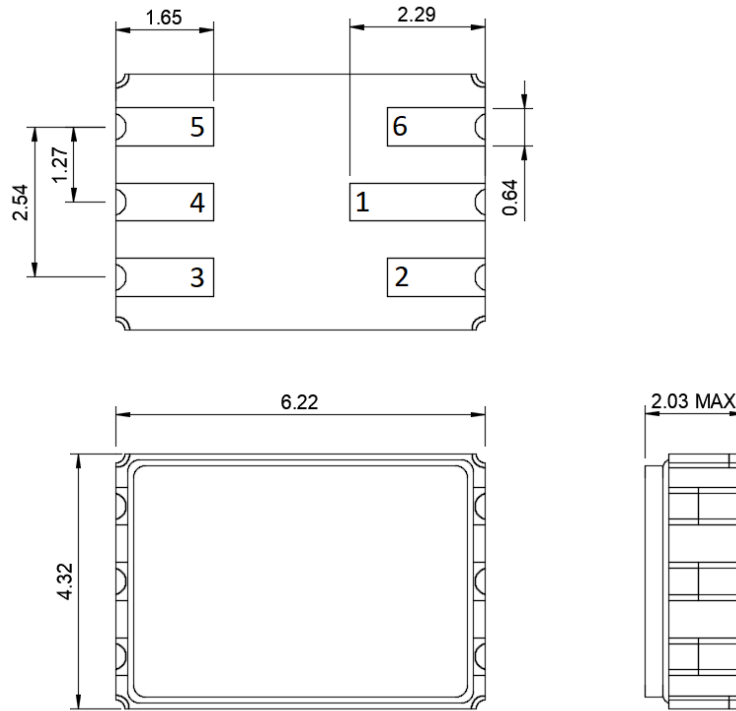

16 Pin Flat Pack

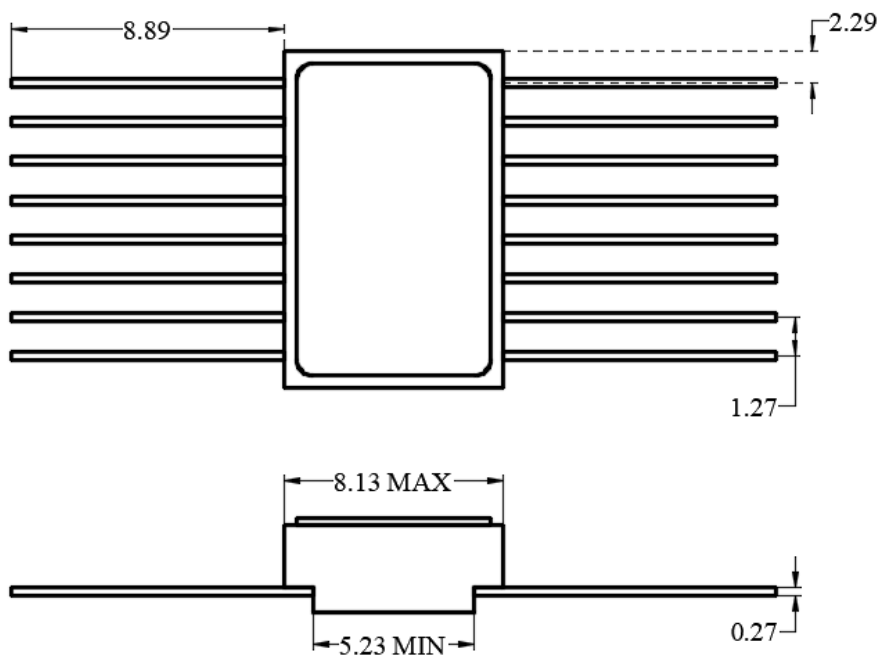

ISOCOM Package Drawings (cont.)

16 Pin DIP

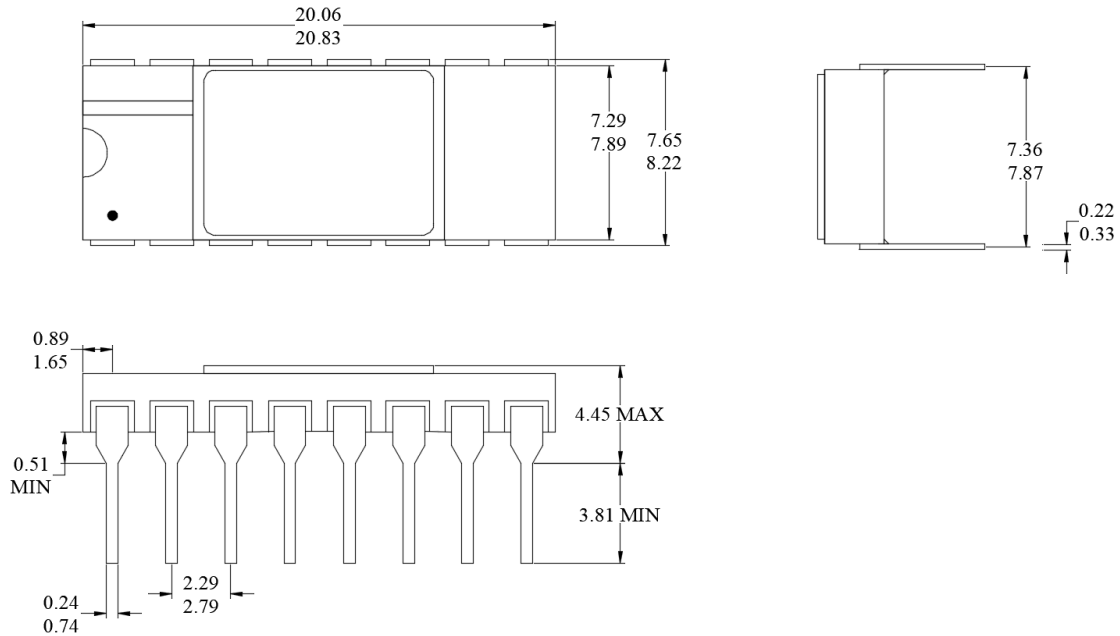

8 Pin DIP

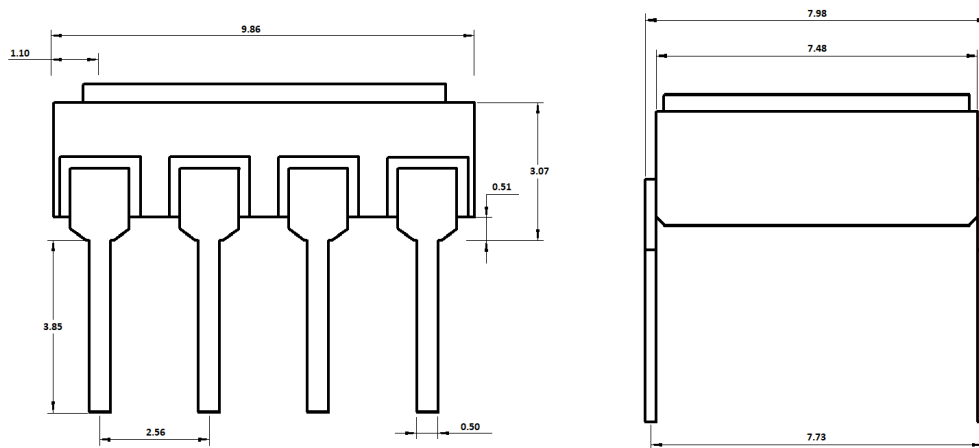

6 Pin DIP

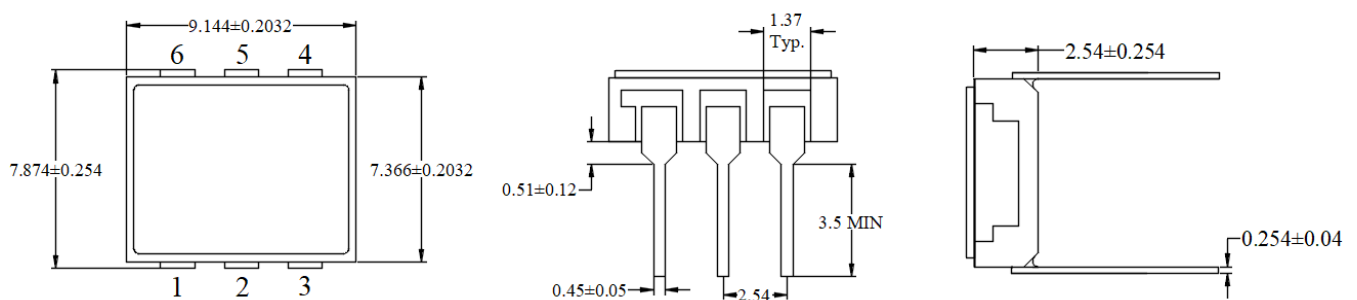

Screening Flow MIL-PRF 19500

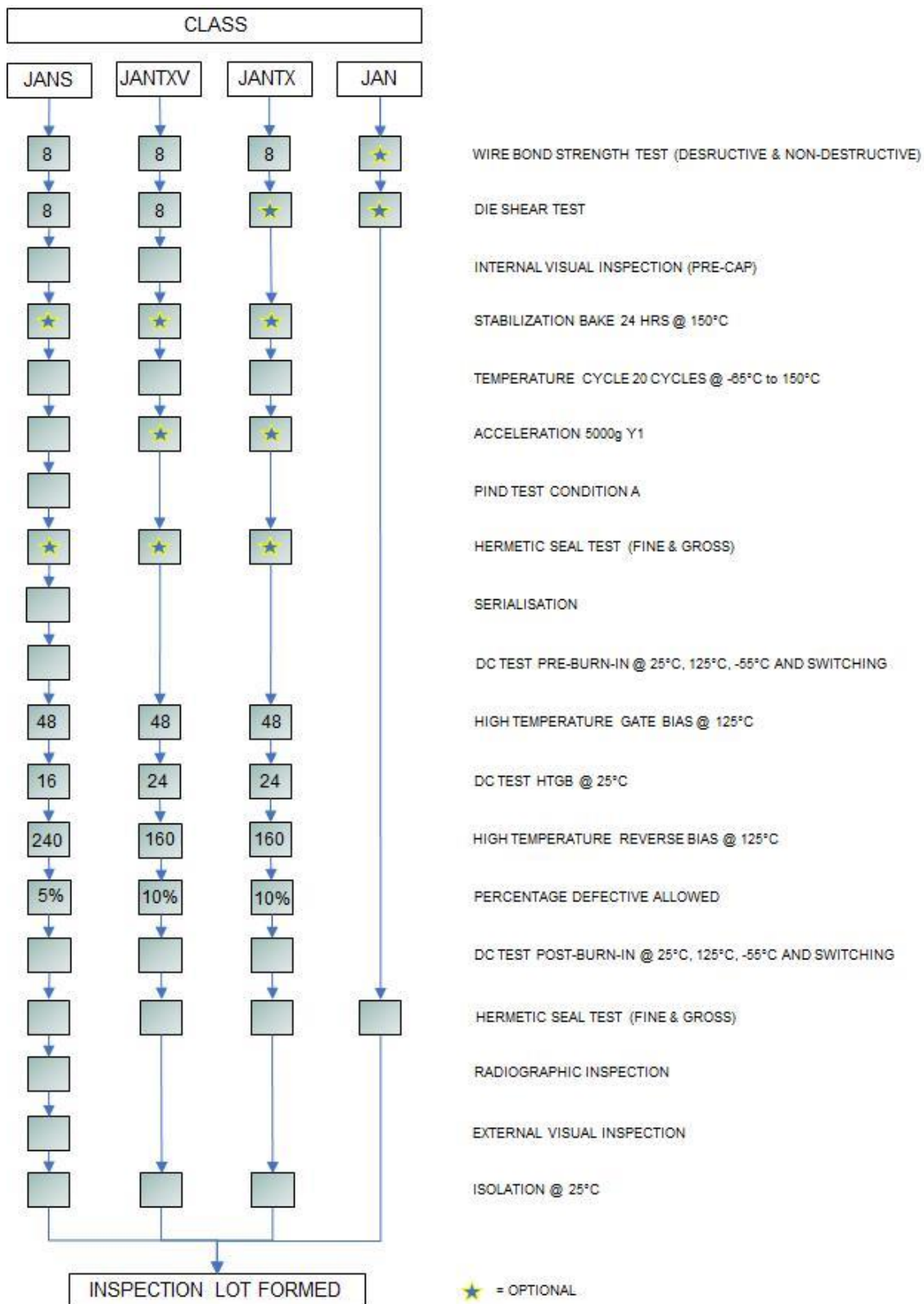

Screening Flow MIL-PRF 38534

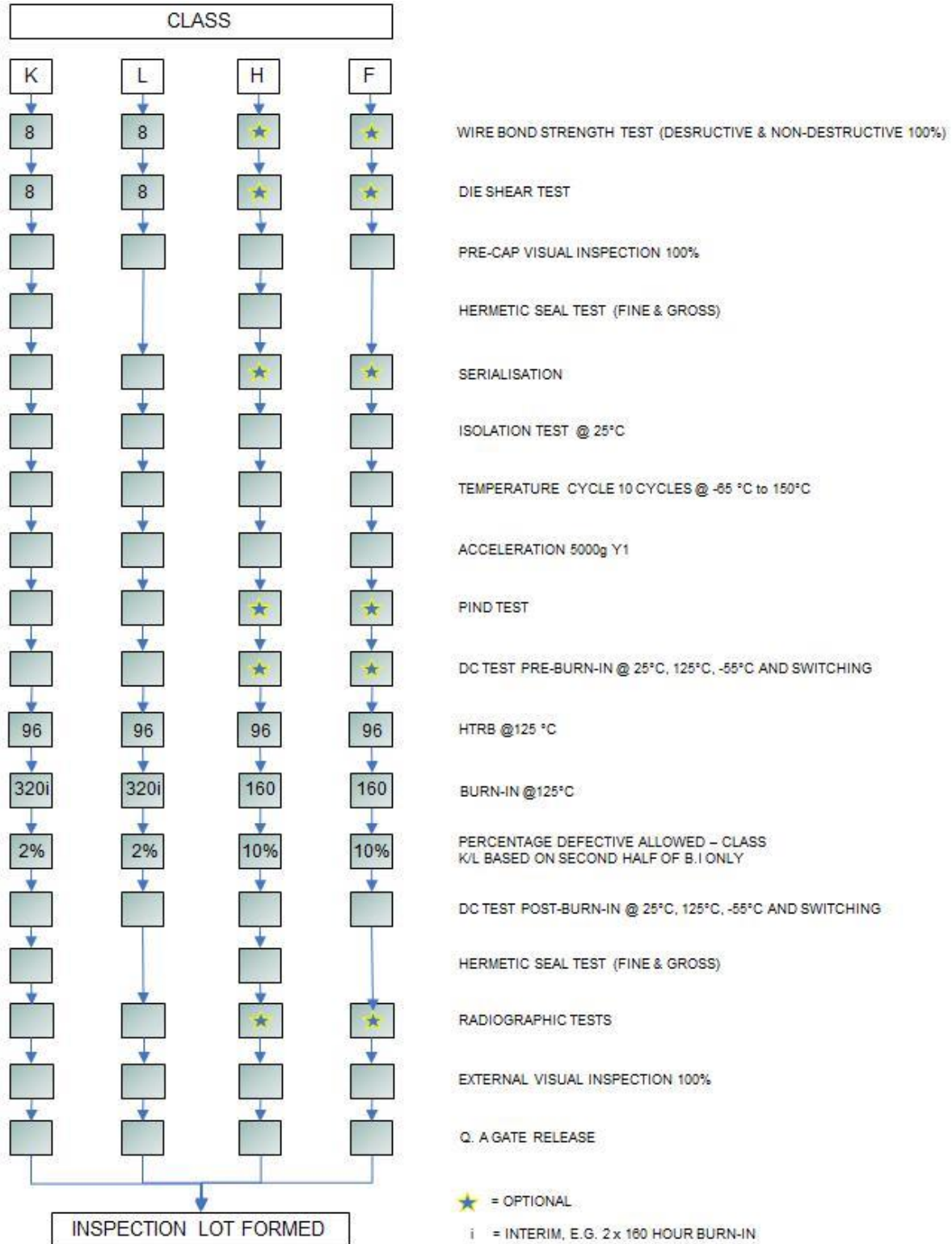



aerospace
sector
certification
scheme



M1077



ISOCOM Limited

2 Fern Court

Peterlee

County Durham

Tyne & Wear

SR8 2RR

United Kingdom

T: +44 (0)191 416 6546

E: sales@isocom.uk.com

www.isocom.uk.com