



State of the Art, Inc.

2470 Fox Hill Road, State College, PA 16803-1797 USA
tel: (814)355-8004 fax: (814)355-2714 www.resistor.com

REACH¹

State of the Art, Inc. produces various resistor products classified as articles per Registration, Evaluation, Authorisation and Restriction of Chemicals, entered into force on 1 June 2007. Some of our products contain substances of very high concern (SVHC) as listed on the Candidate List 209 (last updated on 25 June 2020) published in accordance with Article 59(10) of the REACH Regulation and maintained by the European Chemicals Agency (ECHA). A link to the Candidate List is provided for your convenience. <http://echa.europa.eu/web/guest/candidate-list-table>

Our products may contain substances of very high concern (SVHC). Two SVHC materials are found in some of our products. Lead is found in the tin-lead (SnPb) solder finish found on some surface mount chips. Cadmium, as cadmium oxide, is found in older high power resistors and all resistors with platinum/gold termination finish.

The REACH status of our products is determined by several codes in our product's part number. Our part identification numbers have various formats, examples are shown below:

Semi-precision thick film chip resistors: S1206CPX1000F10, S1206CPY102G30

Precision thin film chip resistors: S1206CA1000BEB, S1206CA1001FKW

Precision silicon chip resistors: S0303AS1000FKW

Zero ohm chip resistors (jumpers): S0402CPX000

Chip attenuators: S0303AC10B0B, S0706CW6B0B, S1512CT3B0BN7

MIL-PRF-55342 chip resistors: M55342K06B100BR, D55342K07W100DT

MIL-PRF-32159 zero ohm chip resistors: M32159C12M, M32159B06T.

MIL-PRF-914 surface mount resistor networks: M914D04K1002FMM

Surface mount resistor networks: SJC20L1001FA, SD1516K1001FB.

¹ Regulation (EC) No 1907/2006 of the European Parliament and of the Council of 18 December 2006 concerning the Registration, Evaluation, Authorisation and Restriction of Chemicals (REACH).

Semi-Precision Thick Film Chip Resistors

The REACH status of semi-precision thick film products is determined by the product and termination finish codes in our part number. These codes are boxed in the part number example below, the boxed P is product type code and the boxed X is the termination finish code.

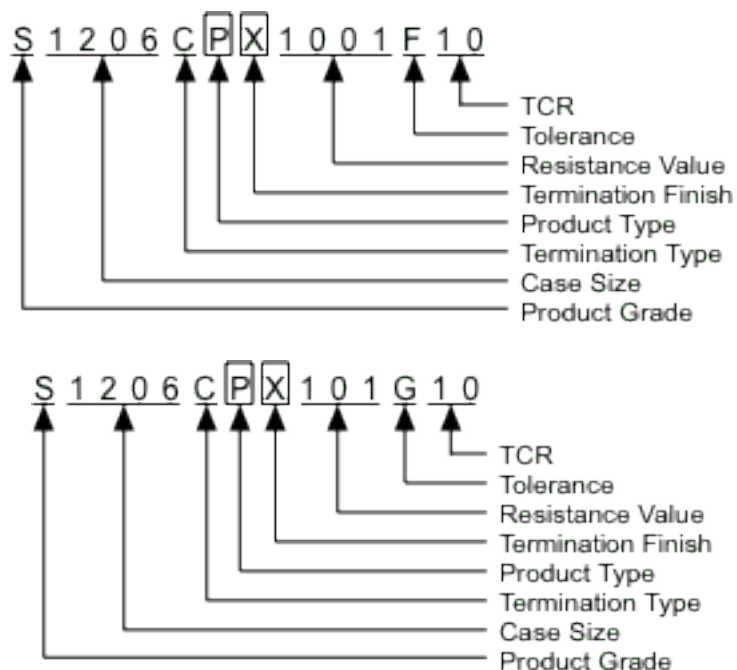

Semi-precision thick film chip resistors with product codes B or R (high power resistors) may contain the SVHC material cadmium as cadmium oxide. Current production does not contain cadmium oxide but older stock does. Older stock does not comply with REACH.

Semi-precision thick film chip resistors with termination finish code P (platinum gold) contain the SVHC material cadmium as cadmium oxide.

Semi-precision thick film chip resistors with termination finish code X (tin-lead solder over nickel barrier) contain the SVHC material lead. Resistors with termination finish code X do not comply with REACH.

All other semi-precision thick film chip resistors do not contain SVHC materials.

Precision Thin Film Chip Resistors

The REACH status of precision thin film chip resistors is determined by the termination finish code. This code is boxed in the part number example below, the boxed B is the termination finish code.

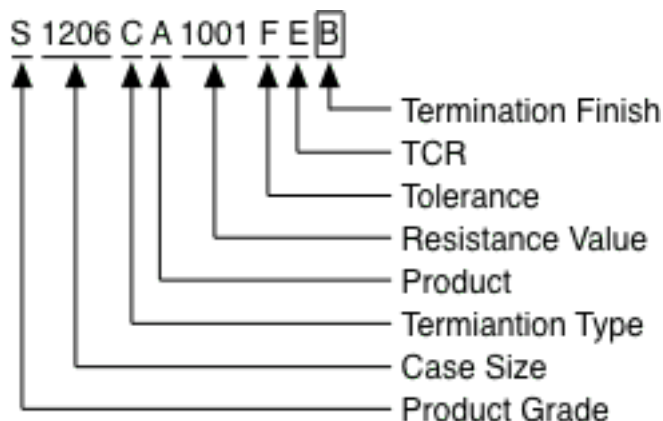

Precision thin film chip resistors with termination finish code B (tin-lead solder over nickel barrier) contain the SVHC material lead. Resistors with termination finish code B do not comply with REACH.

All other precision thin film chip resistors do not contain SVHC materials.

Precision Silicon Resistors

Precision silicon resistors do not contain SVHC materials. Silicon resistors are identified by the product code S in the part number.

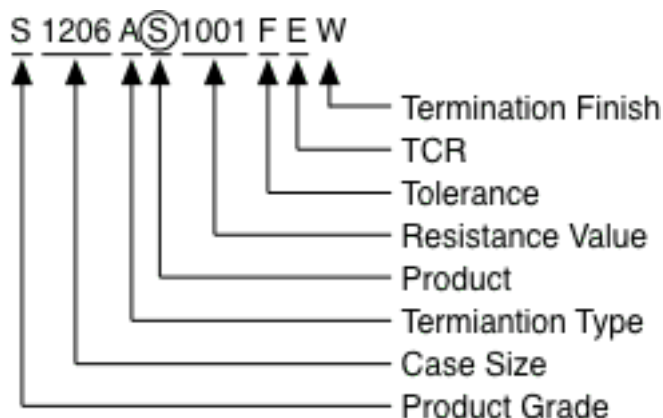

All precision silicon resistors do not contain SVHC materials.

Zero Ohm Chip Resistors (Jumpers)

Zero ohm chip resistors (jumpers) may contain a SVHC (cadmium or lead). REACH status is determined by the termination finish code in the part number. The boxed X is the termination finish code.

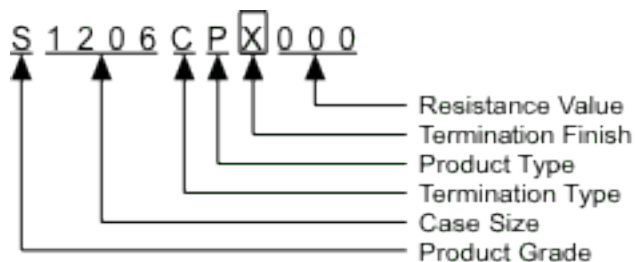

Zero ohm chip resistors with termination finish code X (tin-lead solder over nickel barrier) contain the SVHC material lead. Resistors with termination finish code X do not comply with REACH.

Zero ohm chip resistors with termination finish code P (platinum gold) contain the SVHC material cadmium as cadmium oxide.

All other zero ohm chip resistors do not contain any SVHC materials.

Fixed Attenuators

Fixed chip attenuators may contain a SVHC (lead) and are identified by termination finish code B boxed in the attenuator part number format:

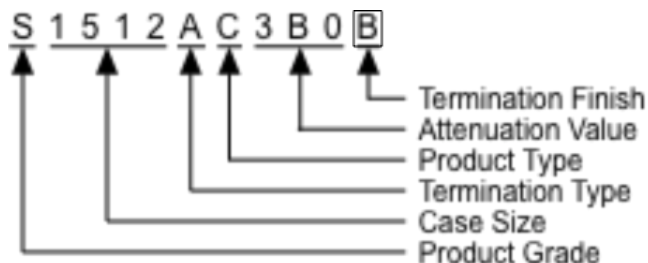

Fixed chip attenuators with termination finish code B (tin-lead solder over nickel barrier) contain the SVHC material lead. Attenuators with termination finish code B do not comply with REACH.

All other fixed chip attenuators do not contain any SVHC materials.

Temperature Variable Attenuators

Temperature variable chip attenuators may contain a SVHC (lead) and are identified by termination finish code B boxed in the attenuator part number format:

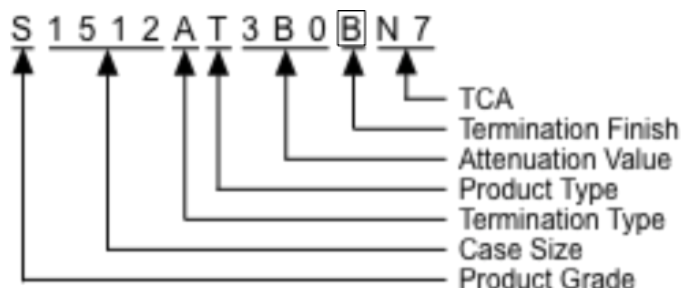

Temperature variable chip attenuators with termination finish code B (tin-lead solder over nickel barrier) contain the SVHC material lead. Attenuators with termination finish code B do not comply with REACH.

All other temperature variable chip attenuators do not contain SVHC materials.

MIL-PRF-55342 Resistors

REACH compliance of MIL-PRF-55342 is determined by the termination material code in the MIL-PRF-55342 part number. The termination material code location is boxed in the part number example.

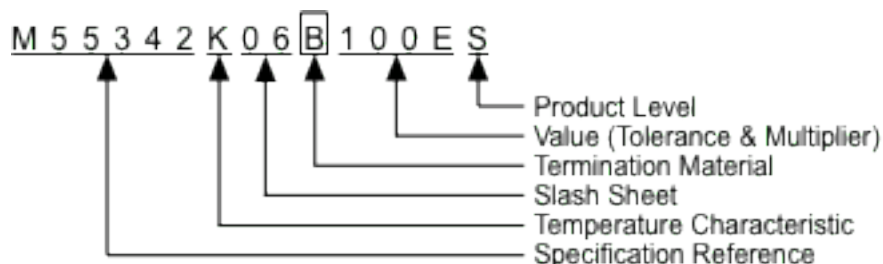

MIL-PRF-55342 chip resistors with termination material U (platinum gold) contains the SVHC material cadmium as cadmium oxide.

MIL-PRF-55342 chip resistors with termination material B (tin-lead solder over nickel barrier) contain the SVHC material lead. Resistors with termination material B do not comply with REACH.

All other MIL-PRF-55342 resistors do not contain SVHC materials.

MIL-PRF-32159 Zero Ohm Jumper Resistors

REACH compliance of MIL-PRF-55342 is determined by the termination material code in the MIL-PRF-55342 part number. The termination material code location is boxed in the part number example.

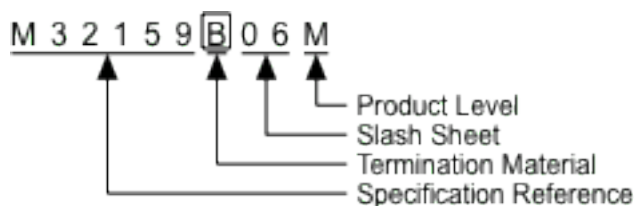

MIL-PRF-32159 zero ohm chip resistors with termination material code U (platinum gold) contain the SVHC material cadmium as cadmium oxide and do not comply with REACH. MIL-PRF-32159 zero ohm chip resistors with termination material code B (tin-lead solder over nickel barrier) contain lead and do not comply with REACH.

All other MIL-PRF-32159 resistors do not contain any of the REACH SVHC materials.

Surface Mount Thick Film Resistor Networks

Surface mount resistor networks contain the SVHC material lead in the tin-lead solder termination finish and do not comply with REACH.

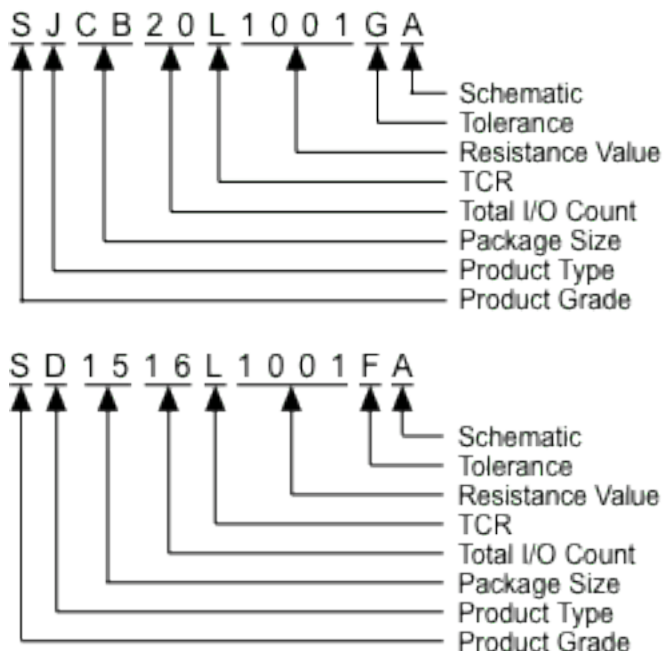

All surface mount resistor network products contain the SVHC lead in the tin-lead solder termination finish and do not comply with REACH.

MIL-PRF-914 Surface Mount Resistor Networks

MIL-PRF-914 thick film surface mount resistor networks contain the SVHC lead in the tin-lead solder termination finish and do not comply with REACH.

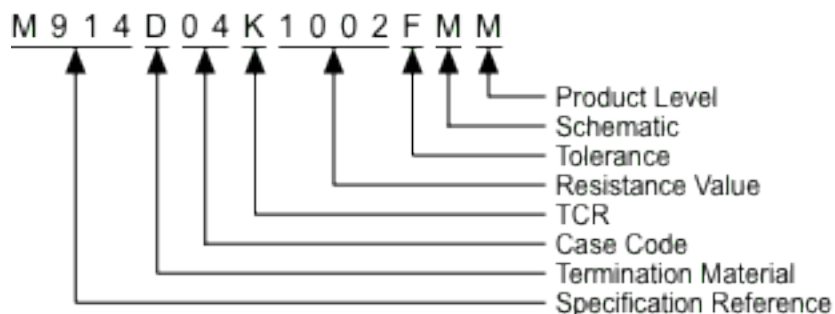

All MIL-PRF-914 surface mount resistor network products contain lead in the tin-lead solder termination finish and do not comply with REACH.