

18-36V Input 15A Output DC-DC Converter



Features

- Remote sense, remote control, over-current and over temperature protections
- Power good signal
- Monotonic start-up
- All components meet UL 94V-0

Options

- Negative / Positive enable logic

Part Numbering System

| NPS | 3 | 009 | □ | 015 | S | 2 | 5 |
|-------------|---------------|----------------|----------------------------|----------------------|--------|-------------------|---|
| Series Name | Input Voltage | Output Voltage | Enabling Logic | Rated Output Current | Pin | Electrical Option | Mechanical Option |
| | 3: 18-36V | 009: 0.9V | P: positive N: negative | 015: 15A | S: SMT | 2: Standard | Lead-free (ROHS-6 Compliant) 5: Standard |

Absolute Maximum Rating

Excessive stresses over these absolute maximum ratings can cause permanent damage to the converter. Operation should be limited to the conditions outlined under the Electrical Specification Section.

| Parameter | Min | Max | Unit |
|-------------------------------|------|-----|------|
| Input Voltage (continuous) | -0.3 | 40 | Vdc |
| PGOOD | -0.3 | 7 | Vdc |
| ON/OFF | -0.3 | 10 | Vdc |
| Operating Ambient Temperature | -40 | 85 | °C |
| Storage Temperature | -55 | 125 | °C |

Electrical Specifications

These specifications are valid over the converter's full range of input voltage, resistive load, and temperature unless noted otherwise.

Input Specifications

| Parameter | Min | Typical | Max | Unit |
|---|-----|---------|-----|------|
| Input Voltage | 18 | 24 | 36 | Vdc |
| Input Current | - | - | 1 | A |
| Quiescent Input Current (Vin=24, Vo=0.9V) | - | 3 | - | mA |

Output Specifications

| Parameter | Min | Typical | Max | Unit |
|---|--------|----------|--------|----------------|
| Output Voltage Set Point (Vin=24V; full load; Ta = 25°C) | - | 0.9 | - | V |
| Output Voltage Set Point Accuracy (over all conditions) | -3 | - | +3 | %Vo |
| Output Regulation: Line Regulation (full range input voltage, 1/2 full load) Load Regulation (full range load, Vin=24V) | - - | - - | 2 2 | %Vo |
| Output Ripple and Noise Voltage RMS Peak-to-peak (5 Hz to 20 MHz bandwidth, Vin=24V) | - - | 15 30 | | mVrms mVp-p |
| Output Current | 0 | - | 15 | A |
| Output Power | 0 | - | 13.5 | W |
| Efficiency (Vin=24V, full load; Ta = 25°C) | 79 | 80 | - | % |
| External Load Capacitance | 220 | | 6,800 | µF |
| Output Over Current Protection Set Point | 15 | - | 28 | A |
| Output Voltage Trim Range | 0.9 | - | 1.1 | V |
| Vbus (the total output power together with 0.9V channel is limited to 20W) | - | 7 | - | V |
| Dynamic Response (Vin=24V; Vo=0.9V, Ta = 25°C; load transient 2.5A/µs) Load steps from 50% to 100% of full load: Peak deviation Load step from 100% to 50% of full load Peak deviation | - - | 20 20 | - - | mV mV |

General Specifications

| Parameter | Min | Typical | Max | Unit |
|---------------|------|---------|-----|------|
| Remote Enable | | - | | |
| Logic Low: | -0.3 | - | 0.3 | V |
| Logic High: | 3.5 | - | 10 | V |



Characteristic Curves

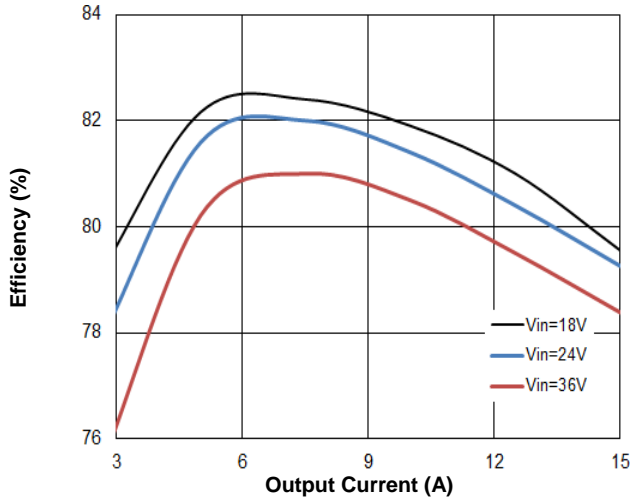

Figure 1. Efficiency vs. Load Current (25°C)

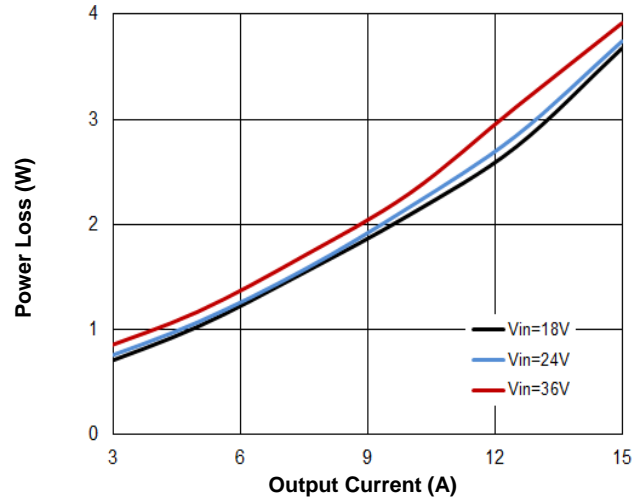

Figure 2. Power Loss vs. Load Current

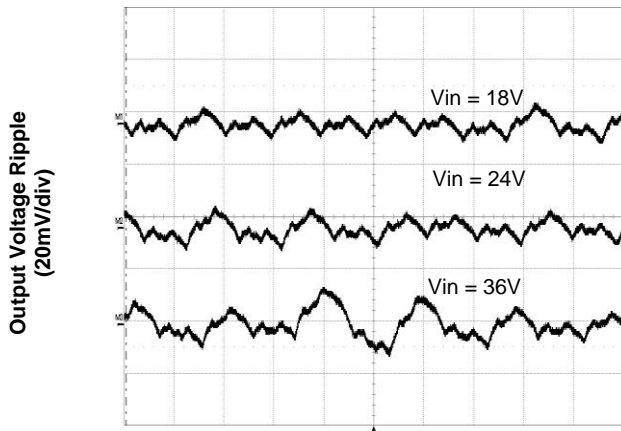

Figure 3. Output Ripple Voltage at Full Load

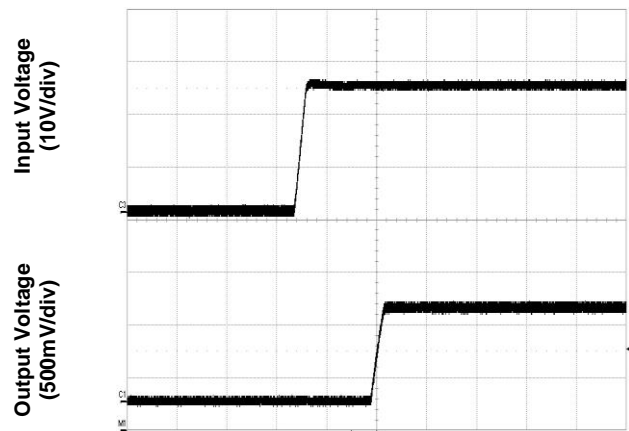

Figure 4. Start-Up from Input Voltage (typical Vin, full load)

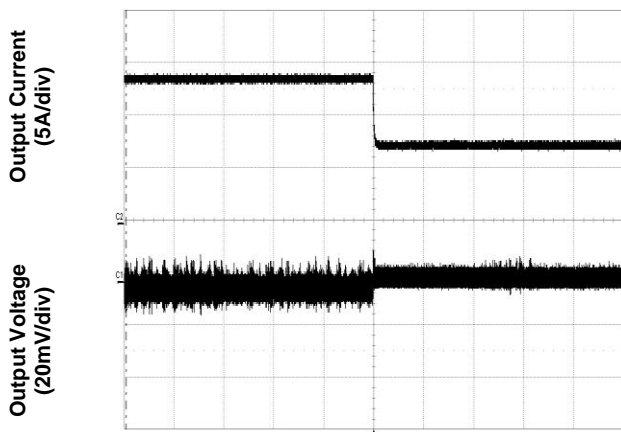

Figure 5. Transient Load Response (typical Vin, load current steps from 50% to 25% at a slew rate 2.5A/µs)

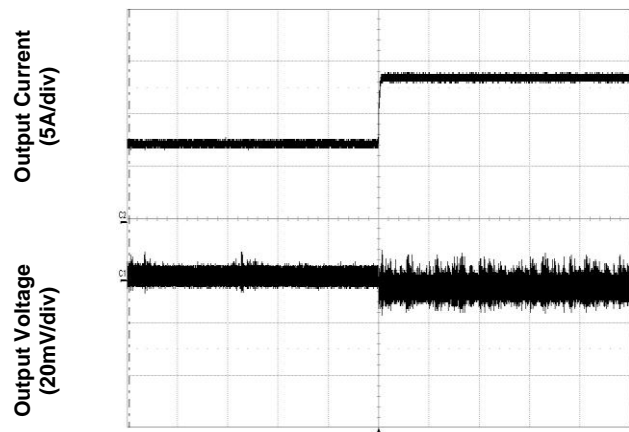

Figure 6. Transient Load Response (typical Vin, load current steps from 25% to 50% at a slew rate 2.5A/µs)

Feature Descriptions

Remote ON/OFF

The converter can be turned on and off by changing the voltage between the ON/OFF pin and GND.

For the negative control logic, the converter is ON when the ON/OFF pin is at a logic low level, and OFF when the ON/OFF pin is at a logic high level. For the positive control logic, the converter is ON when the ON/OFF pin is at a logic high level and OFF when the ON/OFF

Remote SENSE

The remote SENSE pin is used to sense voltage at the load point to accurately regulate the load voltage and eliminate the impact of the voltage drop in the power distribution path.

The SENSE pin should be connected to the point where regulation is desired. The voltage between the output pins must not exceed the operating range of this converter shown in the specification table.

When remote sense is not used, the SENSE pin can be connected to the positive output terminals. If the SENSE pins are left floating, the converter will deliver an output voltage slightly higher than its set point.

Since there is no remote sense on the return path, the voltage drop on the ground (common) connection is not compensated, and it is important to make sure that the return path resistance is sufficiently low so that the voltage drop across it is acceptable without compensation.

Output Voltage Adjustment (Trim)

This converter is available with variable output. The converters are preset to a nominal 0.9V output voltage, and can be trimmed up to 1.2V using an external trim resistor.

To increase the output voltage, a resistor should be connected between the TRIM pin and the GND pin.

$$R_{trim} = \frac{3.066}{V_o - 0.887} (k\Omega)$$

Where V_o is the desired output voltage.

The circuit configuration for trim operation is shown

in Figure. 7. Because NPS converters use GND as the reference for control, R_{trim} should be placed as close to the pin8 or pin9 (GND) as possible, and the trace connecting the GND pin and R_{trim} resistor should not carry significant current, to reduce the effect of voltage drop on the GND trace/plain on the output voltage accuracy.

When the remote sense and the trim functions are used simultaneously, do not allow the output voltage at the converter output terminals to be outside the operating range.

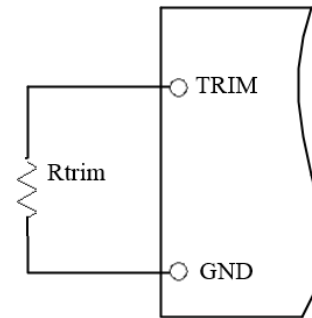

Figure 7. Circuit to Trim Output Voltage

Output Over-Current Protection (OCP)

As a standard feature, the converter turns off when the load current exceeds the current limit. If the over-current or short circuit condition persists, the converter will operate in a hiccup mode (repeatedly trying to restart) until the over-current condition is cleared.

Thermal Shutdown

As a standard feature, the converter will shut down if an over-temperature condition is detected.

The thermal shutdown function is designed to turn the converter off when the temperature at the controller reaches 135°C. The converter will resume operation after the converter cools down.

Power Good

The converter provides a Power Good (PGOOD) signal that is implemented with an open-drain output, in which the high state indicates that the output voltage is within 10% or -5% of its set point. The power-good output is an open drain output and must be pulled up externally.

Vbus

Vbus is an internal bus voltage. If it is used to power a load, a 10uF/25V capacitor is recommended from this pin to pin8 or pin9 (GND), and the total power together with the 0.9V output should not exceed 20W.

Design Considerations

Input Source Impedance and Filtering

The stability of the NPS converters, as with any DC/DC converter, may be compromised if the source impedance is too high or too inductive. It's desirable to keep the input source AC impedance as low as possible. To reduce ripple current getting into the input circuit (especially the ground/return conductor), it is desirable to place some low ESR capacitors at the input. Due to the existence of some inductance (such as the trace inductance, connector inductance, etc) in the input circuit, possible oscillation may occur at the input of the converter. A combination of ceramic capacitors and Tantalum/Polymer capacitors should be used at the input so that the relatively higher ERS of Tantalum/Polymer capacitors can help damp the possible oscillation between the ceramic capacitors and the inductance.

The converter is designed to be stable without additional output capacitors. To further reduce the output voltage ripple and improve the transient response, additional output capacitors are often used in applications. When additional output capacitors are used, a combination of ceramic capacitors and tantalum/polymer capacitors shall be used to provide good filtering while assuring the stability of the converter.



Mechanical Drawing

Open Frame Module

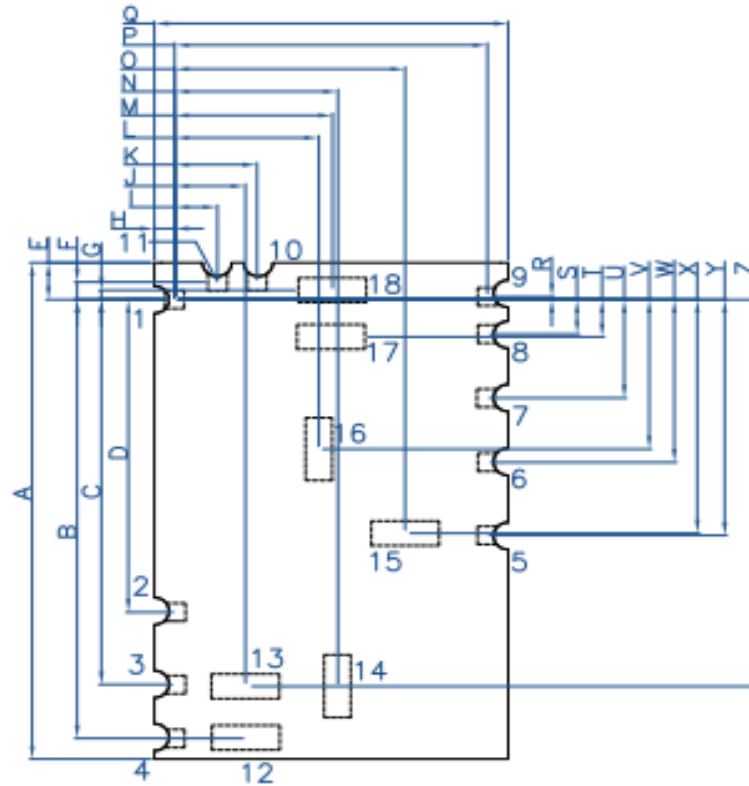

| | |
|---|--------------|
| A | 27.94(1.100) |
| B | 24.71(0.973) |
| C | 21.68(0.854) |
| D | 17.60(0.693) |
| E | 2.07(0.082) |
| F | 0.98(0.039) |
| G | 0.52(0.021) |
| H | 1.05(0.042) |
| I | 2.24(0.088) |
| J | 3.68(0.145) |
| K | 4.29(0.169) |
| L | 7.51(0.296) |
| M | 8.22(0.324) |
| N | 8.47(0.334) |
| O | 12.00(0.473) |
| P | 16.28(0.641) |
| Q | 18.40(0.720) |
| R | 0.15(0.006) |
| S | 1.94(0.077) |
| T | 2.11(0.083) |
| U | 5.55(0.219) |
| V | 8.42(0.332) |
| W | 9.17(0.361) |
| X | 13.16(0.518) |
| Y | 13.28(0.523) |
| Z | 21.78(0.857) |

TOP VIEW

- *PAD 1,2,3,4,5,6,7,8,9,10,11
1.52*1.52mm SQUARE
- ▭—*PAD 12, 13, 14, 15, 16, 17, 18
3.53*1.38mm SQUARE



CUSTOMER BOARD

SIDE VIEW



Recommended Stench Dimension

Recommended Pad Layout

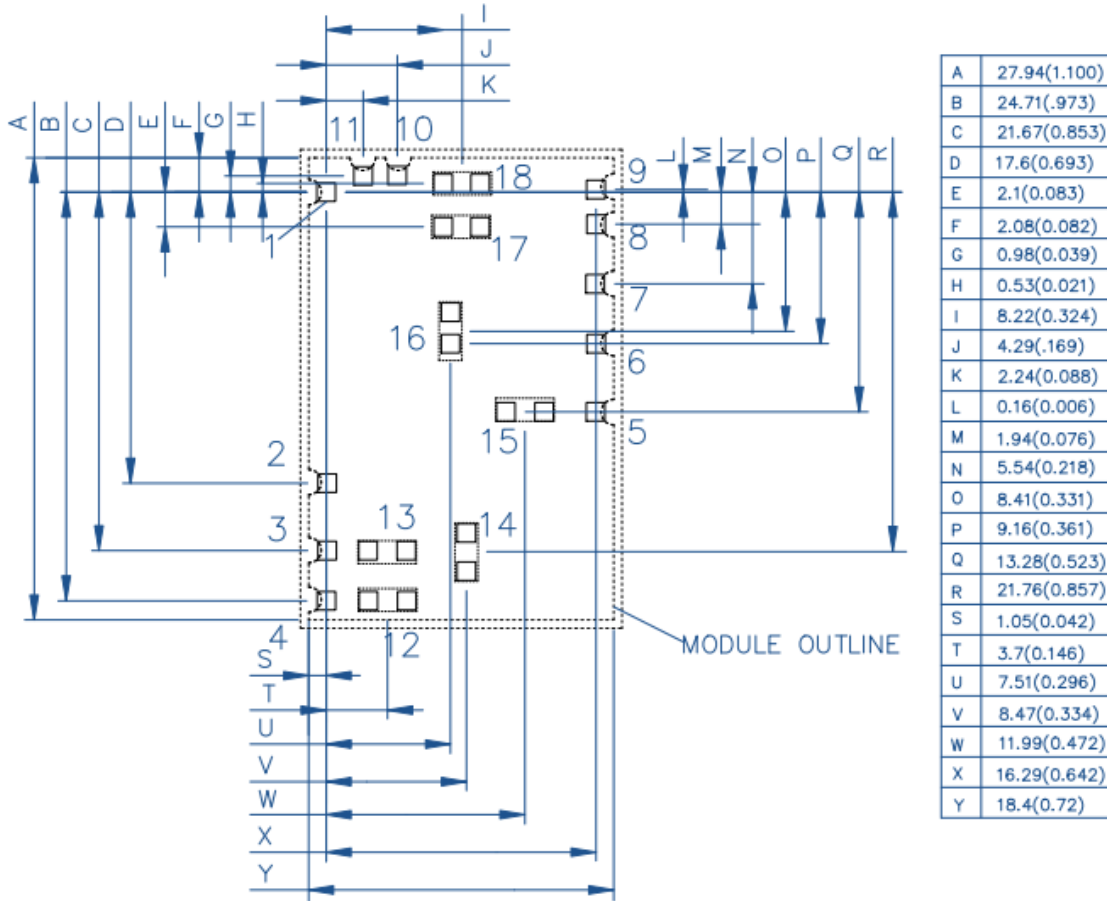

RECOMMENDED 0.5mm GAP AROUND MODULE

□—*PAD1.12*1.12mm SQUARE,25 PLACES.

▭—*12~18 MODULE PAD 3.53*1.38mm SQUARE,7 PLACES.

| Pin | Name | Function |
|-----------------------|----------|-----------------------|
| 1 | PG | Power Good |
| 2 | ON/OFF | Remote control |
| 3,13 | Vin(+) | Input voltage |
| 5,15 | Vbus(+) | Bus voltage |
| 6 | TRIM | Output voltage adjust |
| 7 | SENSE(+) | Remote sense of Vout |
| 4,8,9,12,14, 16,17 | GND | Ground |
| 10,11,18 | Vout(+) | Output voltage |

Notes:

- 1) All dimensions in mm (inches)
Tolerances: .x ± .5 (.xx ± 0.02)
.xx ± .25 (.xxx ± 0.010)
- 2) Workmanship meets or exceeds IPC-A-610 Class II.