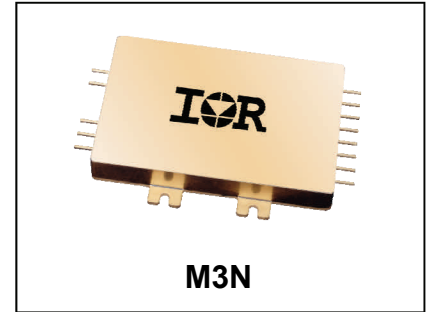

HYBRID-HIGH RELIABILITY RADIATION HARDENED DC-DC CONVERTER

100V Input, Triple Output

Description

M3N-Series is part of the International Rectifier HiRel family of products. The M3N-Series of DC-DC converters are radiation hardened, high reliability converters designed for radiation environments such as those encountered by geosynchronous orbit satellites, deep space probes and communication systems. Features of the M3N-Series include up to 40 watt output power, small size, low weight and a high tolerance to total ionizing dose (TID) and heavy ion single event effects (SEE). They are designed to withstand environmental stresses such as temperature extremes, mechanical shock and vibration. All components are derated to meet the requirements of MIL-STD-975, MIL-STD-1547 and NASA EEE-INST-002. Extensive documentation including thermal, electrical stress, reliability (MTBF), worst case analyses are available.

The converters incorporate a fixed frequency single ended forward topology with magnetic feedback and an internal EMI filter. These converters are capable of meeting the conducted emissions and susceptibility requirements of MIL-STD-461F. They include an external inhibit port and an adjustable output voltage pin. They are encased in a hermetic 3.0" L x 2.0" W x 0.445" H steel package and weigh less than 125 grams. The package utilizes rugged ceramic feed-through copper core pins and is sealed.

Manufactured in a facility fully qualified to MIL-PRF-38534, these converters are fabricated utilizing DLA Land and Maritime qualified processes. For available screening options, refer to device screening table in the data sheet.

Non-flight versions of the M3N-Series converters are available for system development purposes. Variations in electrical specifications and screening to meet custom requirements can be accommodated.

Features

- Total Dose guaranteed to 100 kRads(Si)
- SEE Hardened to LET up to 64 MeV.cm²/mg
- Low Weight < 125 grams
- Low Input and Output Noise
- Magnetically Coupled Feedback
- 65V to 110V DC Input Range
- Up to 40W Output Power
- Triple Output Models Include +5V and ±12V or ±15V
- High Efficiency - to 82%
- -55°C to +125°C Operating Temperature Range
- 100MΩ @ 200VDC Isolation
- Short Circuit and Overload Protection
- Remote Sense on Single Output Models
- Adjustable Output Voltage
- Synchronization Input and Output
- External Inhibit
- > 5,000,000 hour MTBF

Applications

- Geostationary Earth Orbit Satellites (GEO)
- Deep Space Satellites / Probes
- Strategic Weapons and Communication System

Circuit Description

The M3N-Series converters utilize a single-ended forward topology with resonant reset. The nominal switching frequency is 500kHz. Electrical isolation and tight output regulation are achieved through the use of a magnetically coupled feedback. Voltage feed-forward with duty factor limiting provides high line rejection.

An internal EMI filter allows the converter to meet the conducted emissions requirements of MIL-STD-461C on the input power leads. A two-stage output filter reduces the typical output ripple to less than 20mV peak-to-peak.

The main (+5 volt) output is regulated by the control loop and typically exhibits better than 1% regulation. The auxiliary (± 12 volt or ± 15 volt) outputs are maintained through tight coupling in the power transformer and main output filter inductor and typically exhibit better than 5% regulation. The main output and auxiliary outputs are isolated from each other.

Output power is limited under any load fault condition to approximately 125% of rated. An overload condition causes the converter output to behave like a constant current source with the output voltage dropping below nominal. The converter will resume normal operation when the load current is reduced below the current limit point. This protects the converter from both overload and short circuit conditions. The current limit point exhibits a slightly negative temperature coefficient to reduce the possibility of thermal runaway.

An under-voltage lockout circuit prohibits the converter from operating when the line voltage is too low to maintain the output voltage. The converter will not start until the line voltage rises to approximately 62 volts and will shut down when the input voltage drops below 57.5 volts. The 4.5V of hysteresis reduces the possibility of line noise interfering with the converter's start-up and shut down.

An external inhibit port is provided to control converter operation. The nominal threshold relative to the input return (Pin 2) is 1.4V. If 2.0 volts or greater are applied to the Inhibit pin (Pin 3) then the converter will operate normally. A voltage of 0.8V or less will cause converter to shut-down. The pin may be left open for normal operation and has a nominal open circuit voltage of 4.0V.

Synchronization input and output allow multiple converters to operate at a common switching frequency. Converters can be synchronized to one another or to an externally provided clock. This can be used to eliminate beat frequency noise or to avoid creating noise at certain frequencies for sensitive systems.

Design Methodology

The M3N-Series was developed using a proven conservative design methodology which includes selecting radiation tolerant and established reliability components and fully de-rating to the requirements of MIL-STD-1547 and MIL-STD-975 (except for the CDR type ceramic capacitors, where capacitors with 50V ratings may be used with voltage stresses of less than 10V). Careful sizing of decoupling capacitors and current limiting resistors minimizes the possibility of photo-current burn-out. Heavy de-rating of the radiation hardened power MOSFET virtually eliminates the possibility of SEGR and SEB. A magnetic feedback circuit is utilized instead of opto-couplers to minimize temperature, radiation and aging sensitivity. PSpice and RadSpice were used extensively to predict and optimize circuit performance for both beginning and end-of-life. Thorough design analyses include Radiation Susceptibility (TREE), Worst Case, Stress, Thermal, Failure Modes and Effects (FMEA) and Reliability (MTBF).

Specifications

Absolute Maximum Ratings		Recommended Operating Conditions	
Input Voltage	-0.5V _{DC} to +120V _{DC}	Input Voltage range ¹	+65V _{DC} to +110V _{DC}
Output power	Internally limited	Output power	0 to Max. Rated
Lead Temperature	+300°C for 10 seconds	Operating temperature ²	-55°C to +125°C
Operating temperature	-55°C to +135°C	Operating temperature ¹	-55°C to +70°C
Storage temperature	-55°C to +135°C		

¹ Meets de-rating per MIL-STD-975

² For operation at +125°C see table, Note 15

Electrical Performance Characteristics

Parameter	Group A Subgroup	Conditions -55°C ≤ T _C ≤ +85°C V _{IN} = 100V _{DC} ± 5%, C _L = 0 unless otherwise specified	Limits			Unit
			Min	Nom	Max	
Input Voltage (V _{IN})	1,2,3	Note 2	65	100	110	V
Output Voltage (V _{OUT}) (main) M3N1000512T (aux.) M3N1000515T (aux.) (main) M3N1000512T (aux.) M3N1000515T (aux.)	1 2,3	I _{OUT} = 100% rated load, Note 5	4.98 ±11.50 ±14.60	5.00 ±11.80 ±14.90	5.02 ±12.10 ±15.20 5.07 ±12.30 ±15.40	V
Output power (P _{OUT})	1,2,3	V _{IN} = 65, 100, 110 Volts, Note 2	0		40	W
Output current (I _{OUT}) (main) M3N1000512T (aux.) M3N1000515T (aux.)	1,2,3	V _{IN} = 65, 100, 110 Volts, Notes 2,3,4,5	400 ±83 ±67		4000 ±833 ±667	mA
Line regulation (VR _{LINE}) (main) M3N1000512T (aux.) M3N1000515T (aux.)	1,2,3	V _{IN} = 65, 100, 110 Volts I _{OUT} = 10, 50%, 100% rated Note 5, 14	-10 -320 -350		10 320 350	mV
Load regulation (VR _{LOAD}) (main) M3N1000512T (aux.) M3N1000515T (aux.)	1,2,3	I _{OUT} = 10%, 50%, 100% rated V _{IN} = 65, 100, 110 Volts, Notes 5, 13	-50 -400 -500		50 400 500	mV
Cross regulation (VR _{CROSS}) (main) M3N1000512T (aux.) M3N1000515T (aux.)	1,2,3	V _{IN} = 65, 100, 110 Volts I _{OUT} = 2.5A to 1A and 2.5 to 4A on main and ± half rated on aux. outputs	-3.5 -3.0		3.5 3.0	%
Input current (I _{IN})	1,2,3	I _{OUT} = 0, Pin 3 open Pin 3 shorted to Pin 2		35 2.0	50 5.0	mA

For Notes to Electrical Performance Characteristics, refer to page 5

Electrical Performance Characteristics (continued)

Parameter	Group A Subgroup	Conditions -55°C ≤ T _C ≤ +85°C V _{IN} = 100V _{DC} ± 5%, C _L = 0 unless otherwise specified	Limits			Unit
			Min	Nom	Max	
Output ripple (V _{RIP}) (main) M3N100512T (aux.) M3N100515T (aux.)	1,2,3	V _{IN} = 65, 100, 110 Volts I _{OUT} = 100% rated load, Notes 5, 6		25 30 30	50 60 75	mVp-p
Switching frequency (F _s)	1,2,3	Sych. Input (Pin4) open	450	500	550	kHz
Efficiency (E _{FF})	1,2,3	I _{OUT} = 100% rated load Note 5	78	82		%
Inhibit input open circuit voltage drive current (sink) voltage range		Note 1	3.0 -0.5		5.0 100 50	V μA V
Synchronization input frequency range pulse high level pulse low level pulse transition time pulse duty cycle		Ext. Clock on Sync. Input (Pin 4) Note 1	450 4.0 -0.5 40 20		600 10 0.5 80	kHz V V V/μs %
Current Limit Point Expressed as a percentage of full rated output power	1,2,3	V _{OUT} = 90% of Nominal, Note 5			135	%
Power dissipation, load fault (P _D)	1,2,3	Short Circuit, Overload, Note 8			20	W
Output response to step load changes (V _{TLD})	4,5,6	Half Load to/from Full Load, Notes 5, 9	-300		300	mVpk
Recovery time, step load changes (T _{TLD})	4,5,6	Half Load to/from Full Load, Note 5,9,10		50	200	μs
Output response to step line changes (V _{TLN})		65V to/from 110V I _{OUT} = 100% rated load, Notes 1,5,11	-300		300	mVpk
Recovery time, step line changes (T _{TLN})		65V to/from 110V I _{OUT} = 100% rated load, Notes 1,5,10,11		50	200	μs
Turn-on Response Overshoot (V _{OS}) (main) (aux.) Turn-on Delay (T _{DLY})	4,5,6	No Load, Full Load, Notes 5,12			500 750	mV mV
Capacitive load (C _L) (main) (Each aux. output)		I _{OUT} = 100% rated load, No effect on DC performance, Notes 1, 5, 7			1000 200	μF

For Notes to Electrical Performance Characteristics, refer to page 5

Electrical Performance Characteristics (continued)

Parameter	Group A Subgroup	Conditions -55°C ≤ T _C ≤ +85°C V _{IN} = 100V _{DC} ± 5%, C _L = 0 unless otherwise specified	Limits			Unit
			Min	Nom	Max	
Line rejection		DC to 50kHz, Notes 1, 5 I _{OUT} = 100% rated load	40	60		dB
Isolation	1	Input to Output or any pin to case Except Pin 10, test @ 200V _{DC}	100			MΩ
Device weight					125	g
MTBF		MIL-HDBK-217F2, SF, 35°C, Note 16	5 x 10 ⁶			Hrs

Notes: Electrical Performance Characteristics Table

- Parameter is tested as part of design characterization or after design changes. Thereafter, parameter shall be guaranteed to the limits specified.
- Parameter verified during line and load regulation tests.
- Although operation with no load is permissible, light loading on the main (+5 volt) output may cause the output voltage of the auxiliary outputs (±12 volt or ±15 volt) to drop out of regulation. It is therefore recommended that at least 200mA or 20 percent of the total output power, whichever is greater, be taken from the main (+5 volt) output.
- Although operation with no load is permissible, heavy loading on the main (+5 volt) output may cause the output voltage of the auxiliary outputs (±12 volt or ±15 volt) to rise out of regulation. It is therefore recommended that at least 50mA or 20 percent of the total output power, whichever is greater, be taken from the auxiliary (±12 volt or ±15 volt) outputs.
- Unless otherwise specified, "Rated" load is 20W on the main (+5 volt) output and 10 watts each on the auxiliary (±12 volt or ±15 volt) outputs. Load currents of up to 5A and ±1A on the main and auxiliary outputs respectively are acceptable as long as the total output power does not to exceed 40 watts.
- Guaranteed for a D.C. to 20MHz bandwidth. Tested using a 20kHz to 10MHz bandwidth.
- Capacitive load may be any value from 0 to the maximum limit without compromising dc performance.
A capacitive load in excess of the maximum limit may interfere with the proper operation of the converter's overload protection, causing erratic behavior during turn-on.
- Overload power dissipation is defined as the device power dissipation with the load set such that V_{OUT} = 90% of nominal.
- Load step transition time ≥ 10 μs.
- Recovery time is measured from the initiation of the transient to where V_{OUT} has returned to within ±1% of its steady state value.
- Line step transition time ≥ 100 μs.
- Turn-on delay time from either a step application of input power or a logic low to a logic high transition on the inhibit pin (Pin 3) to the point where V_{OUT} = 90% of nominal.
- Load Regulation relative to output voltage at 50% rated load.
- Line Regulation relative to output voltage at 100V_{DC} input.
- Although operation at temperatures between +85°C and +125°C is guaranteed, no parametric limits are specified.
- For class K devices.

Radiation Performance Characteristics

Test	Conditions	Min	Typ	Max	Unit
Total Ionizing Dose (Gamma)	MIL-STD-883, Method 1019 Operating bias applied during exposure, Full Rated Load, $V_{IN} = 100V$	100		450	kRads(Si)
Single Event Effects SEU, SEL, SEGR, SEB ^①	Heavy ions (LET) Operating bias applied during exposure, Full Rated Load, $V_{IN} = 100V$ ^②	58	61	64	MeV·cm ² /mg

Notes:

- ① Output perturbation is less than $\pm 5\%$ of nominal output voltage.
- ② Beam conditions: LET = $61 \pm 5\%$ MeV·cm²/mg.

Fig 1. Block Diagram

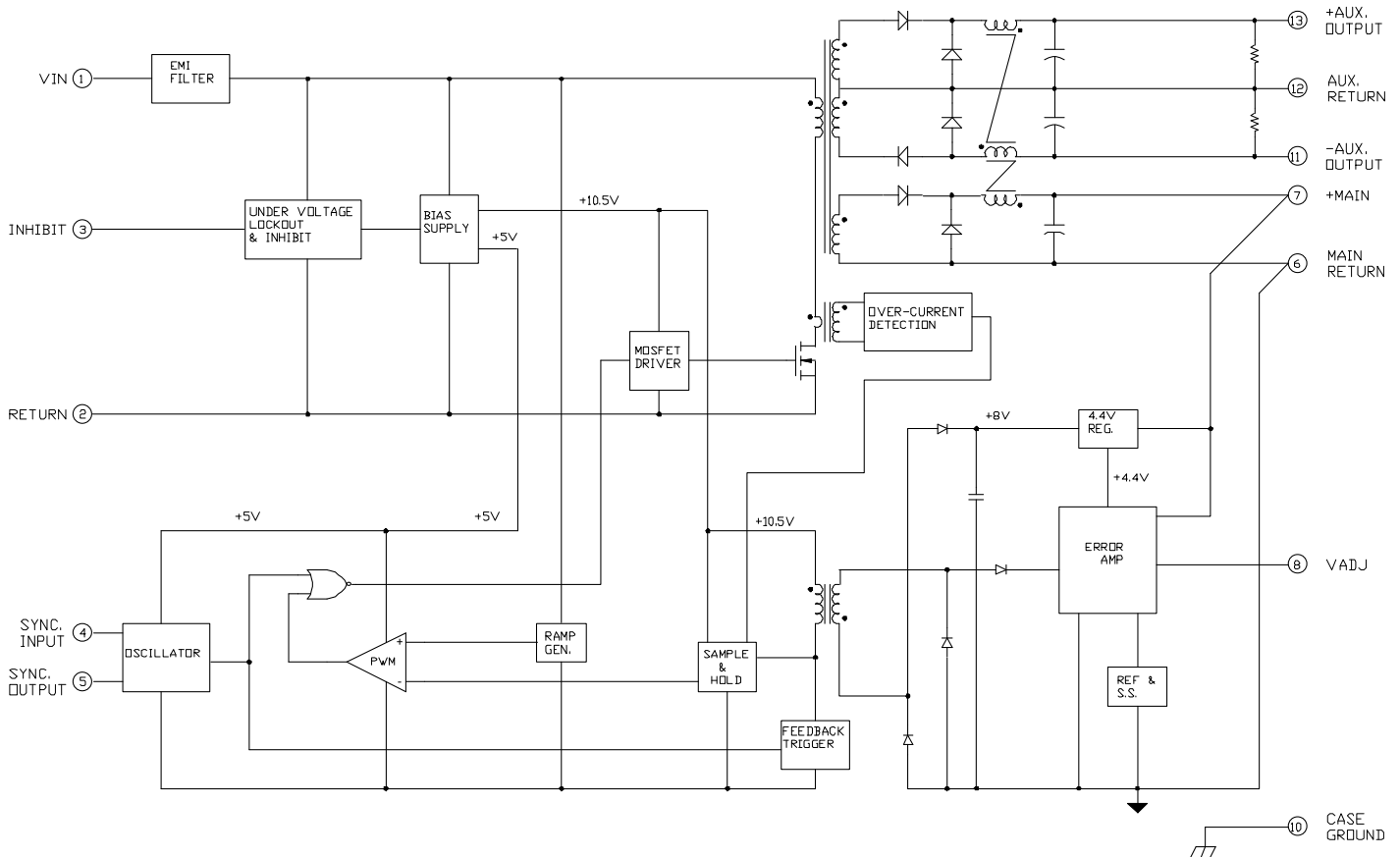

Fig. 2. $\pm 12V$ Load Regulation vs 5V Load

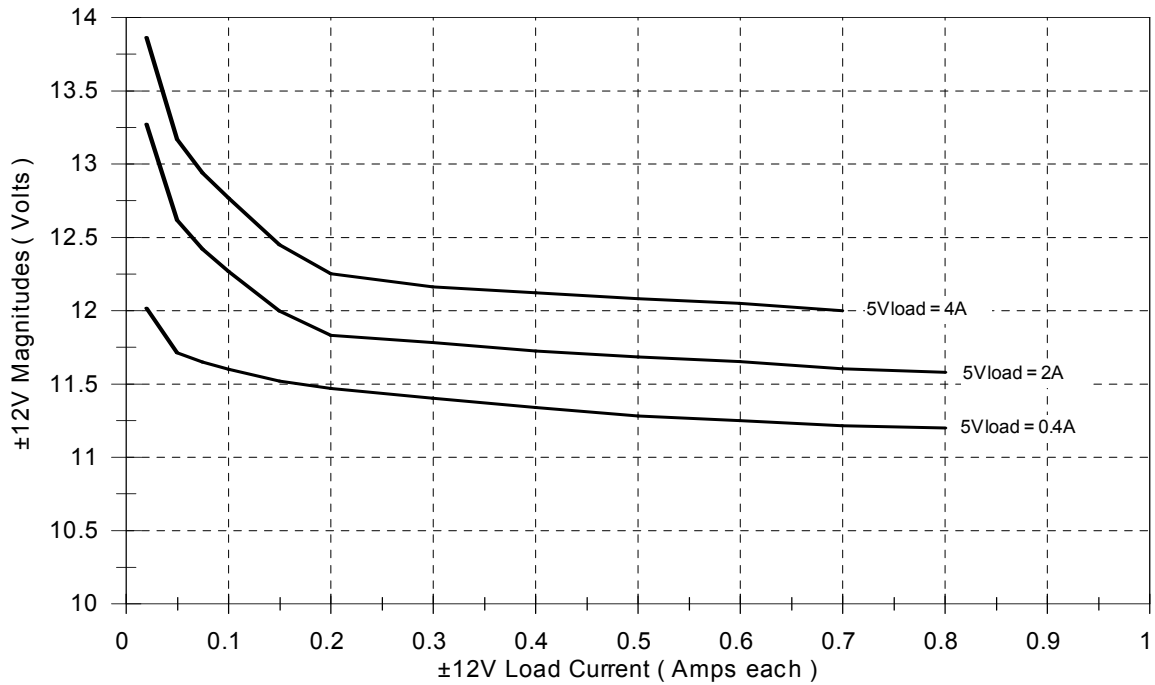
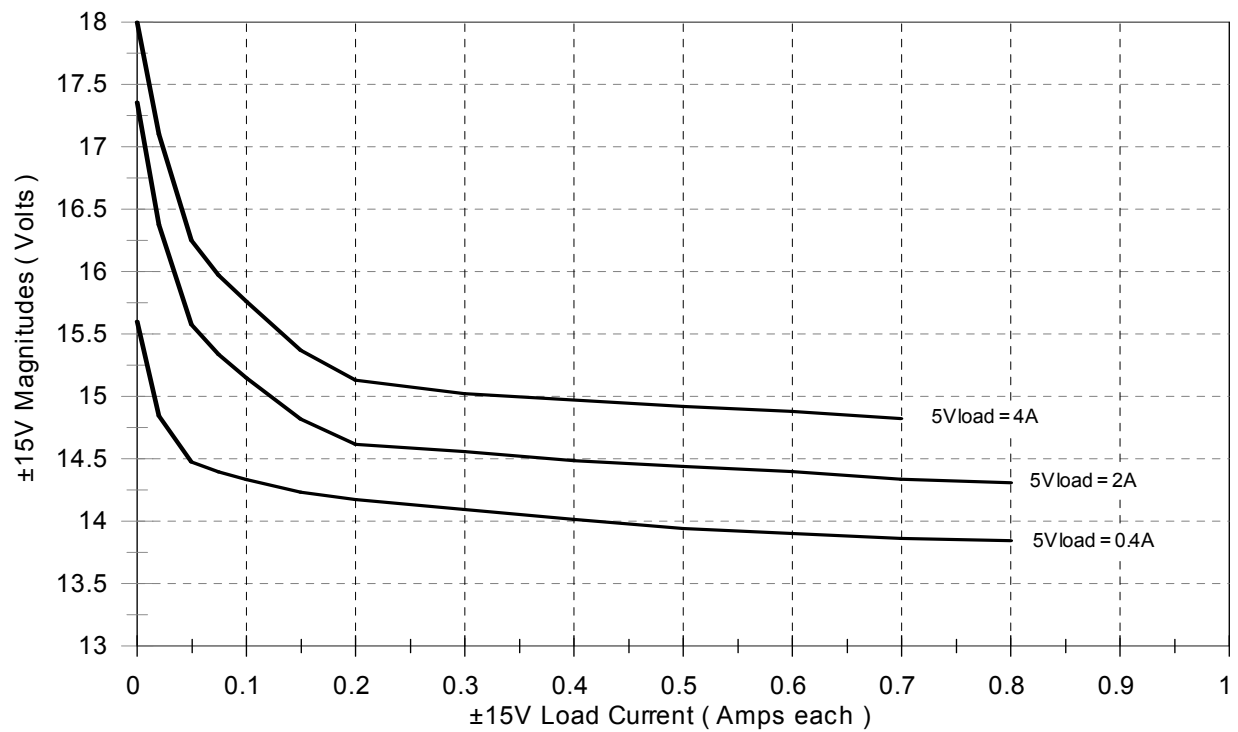

Fig. 3. $\pm 15V$ Load Regulation vs 5V Load



Application Notes:

A) Attachment of the Converter

The following procedure is recommended for mounting the converter for optimum cooling and to circumvent any potential damage to the converter.

Ensure that flatness of the plate where M3N converter to be mounted is no greater than 0.003" per linear inch. It is recommended that a thermally conductive gasket is used to promote the thermal transfer and to fill any voids existing between the two surfaces. IR HiRel recommends Sil-Pad 2000 with the thickness of 0.010". The shape of the gasket should match the footprint of the converter including the mounting flanges. The gasket is available from IR HiRel. The M3N-Series converter requires either M3 or 4-40 size screws for attachment purposes

The procedure for mounting the converter is as follows:

1. Check the mounting surfaces and remove foreign material, burrs if any or anything that may interfere with the attachment of the converter.
2. Place the gasket on the surface reserved for the converter and line it up with the mounting holes.
3. Place the converter on the gasket and line both up with mounting holes.
4. Install screws using appropriate washers and tighten by hand (~ 4 in·oz) in the sequence shown below.
5. Tighten the screws with an appropriate torque driver. Torque the screws up to 6 in·lb in the sequence shown below.

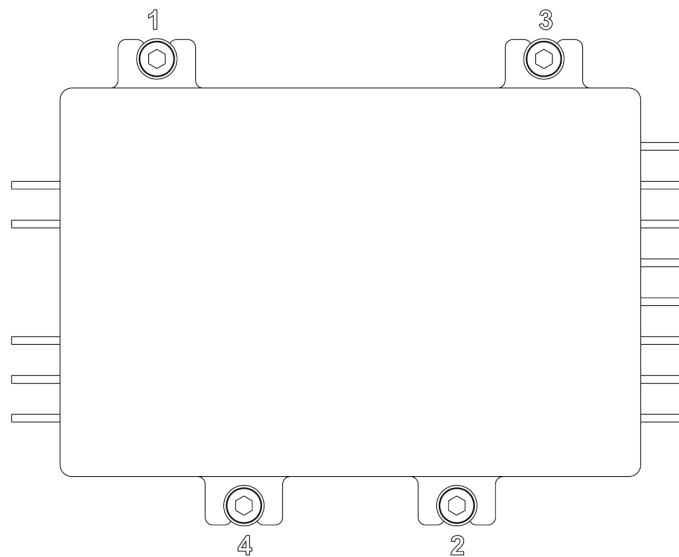

B) Output Voltage Adjustment

To adjust the output voltage, a resistor (R_{ADJ}) is connected between the Adjust pin (Pin 8) and either the, Main Return or Main Out pins depending on whether the output voltage is to be adjusted higher or lower than the nominal set-point. This allows the outputs to be reliably adjusted by approximately +10% to -20% of the nominal output voltage. Refer to Fig. 4 and use equations provided to calculate the required resistance (R_{ADJ}). Please note that the auxiliary output voltages will track the voltage of the main output, higher or lower than the set points by the same percentage of adjustment.

Fig 4. Configuration for Adjusting Triple Output Voltage

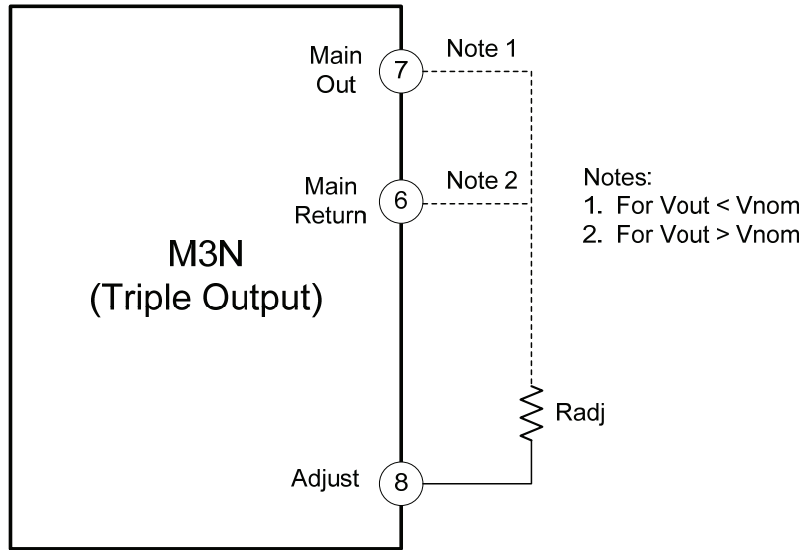

For **all Triple Output Models**, to adjust the output voltages higher:

$$R_{ADJ} = \frac{10 \times (V_{NOM} - 2.5)}{V_{OUT} - V_{NOM}} - 50$$

Where: R_{ADJ} is in kOhms

R_{ADJ} is connected to the -Out pin and $V_{NOM} < V_{OUT} < 1.1V_{NOM}$ (Fig. 4, Note 2)

V_{NOM} is the nominal output voltage with the Adjust Pin left open

V_{OUT} is the desired output voltage

For **all Triple Output Models**, to adjust the output voltages lower:

$$R_{ADJ} = \frac{4 \times (V_{NOM} - 2.5) \times (V_{OUT} - 2.5)}{V_{NOM} - V_{OUT}} - 50$$

Where: R_{ADJ} is in kOhms

R_{ADJ} is connected to the +Out pin and $0.8V_{NOM} < V_{OUT} < V_{NOM}$ (Fig. 4, Note 1)

V_{NOM} is the nominal output voltage with the Adjust Pin left open

V_{OUT} is the desired output voltage

Mechanical Outline

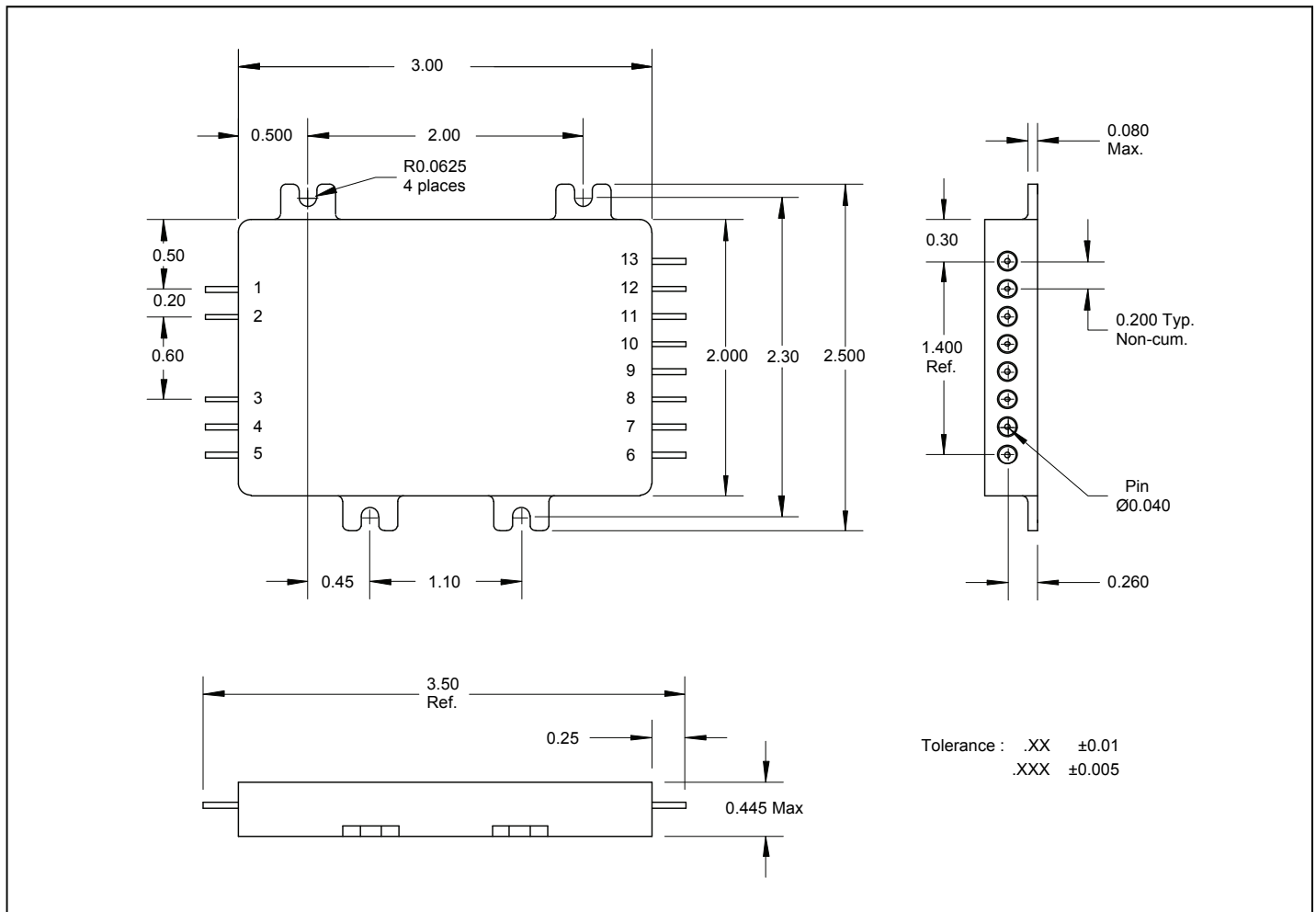

Pin Designation

Pin #	Designation	Pin #	Designation
1	+ Input	8	Adjust
2	Input Return	9	NC
3	Inhibit	10	Case Ground
4	Sync. Input	11	- Aux Output
5	Sync. Output	12	Aux Output Return
6	Main Return	13	+ Aux Output
7	+ Main Output		

Device Screening

Requirement	MIL-STD-883 Method	EM ①	No Suffix ②
Temperature Range	—	-55°C to +85°C	-55°C to +85°C
Element Evaluation	MIL-PRF-38534	N/A	Class K
Non-Destructive Bond Pull	2023	N/A	Yes
Internal Visual	2017	①	Yes
Temperature Cycle	1010	Cond C	Cond C
Constant Acceleration	2001, Y1 Axis	3000 Gs	3000 Gs
PIND	2020	N/A	Cond A
Burn-In	1015	48 hrs @ 125°C	320 hrs @ 125°C (2 x 160 hrs)
Final Electrical (Group A)	MIL-PRF-38534 & Specification	-55°C, +25°C, +85°C	-55°C, +25°C, +85°C
PDA	MIL-PRF-38534	N/A	2%
Seal, Fine and Gross	1014	Cond A	Cond A, C
Radiographic	2012	N/A	Yes
External Visual	2009	IR HiRel Defined	Yes

Notes:

- ① Any Engineering Model (EM) built with the “EM” Suffix shall only be form, fit and functional equivalent to its Flight Model (FM) counterpart, and it may not meet the radiation performance. The EM Model shall not be expected comply with MIL-PRF-38534 flight quality/workmanship standards, and configuration control. An EM build may use electrical equivalent commercial grade components. IR HiRel will provide a list of non-compliant items upon request.
- ② “No Suffix” designator indicates compliant items to class K screening as defined in the MIL-PRF-38534 but does not necessarily deem it to be a SMD part per MIL-PRF-38534.

Part Numbering

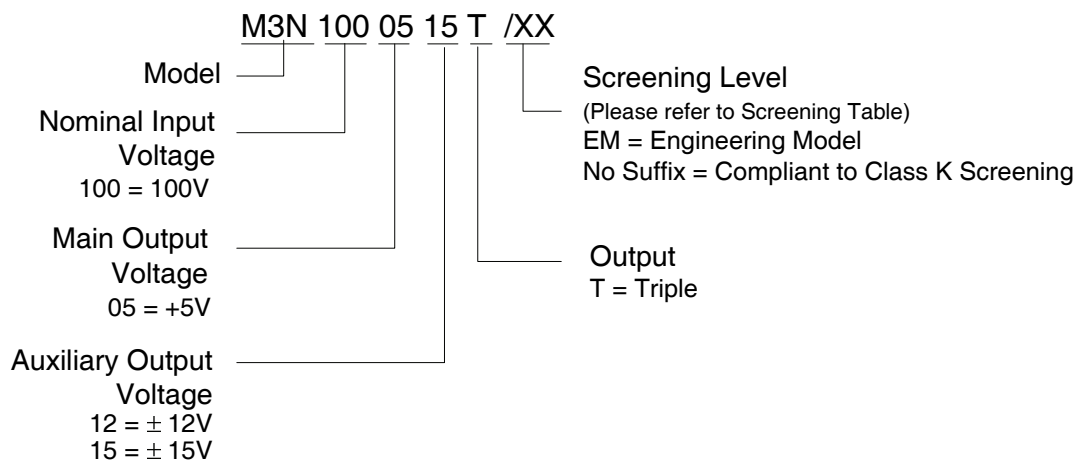

IMPORTANT NOTICE

The information given in this document shall be in no event regarded as guarantee of conditions or characteristic. The data contained herein is a characterization of the component based on internal standards and is intended to demonstrate and provide guidance for typical part performance. It will require further evaluation, qualification and analysis to determine suitability in the application environment to confirm compliance to your system requirements.

With respect to any example hints or any typical values stated herein and/or any information regarding the application of the product, Infineon Technologies hereby disclaims any and all warranties and liabilities of any kind including without limitation warranties on non- infringement of intellectual property rights and any third party.

In addition, any information given in this document is subject to customer's compliance with its obligations stated in this document and any applicable legal requirements, norms and standards concerning customer's product and any use of the product of Infineon Technologies in customer's applications.

The data contained in this document is exclusively intended for technically trained staff. It is the responsibility of any customer's technical departments to evaluate the suitability of the product for the intended applications and the completeness of the product information given in this document with respect to applications.

For further information on the product, technology, delivery terms and conditions and prices, please contact your local sales representative or go to (www.infineon.com/hirel).

WARNING

Due to technical requirements products may contain dangerous substances. For information on the types in question, please contact your nearest Infineon Technologies office.